



Seiko 4K25A,4K26A Movement Parts (1)

Compiled by EmmyWatch - <https://www.emmywatch.com>

PARTS CATALOGUE/ TECHNICAL GUIDE

Cal. 4K25A

Cal. 4K26A

[SPECIFICATIONS]

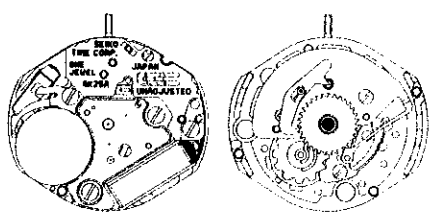
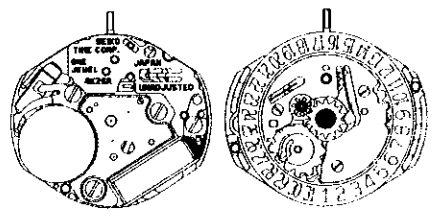
Cal. No.		4K25A	4K26A
Item			
Movement		 (x 1.5)	 (x 1.5)
Movement size	Outside diameter	15.3 mm between 3 o'clock and 9 o'clock sides 17.6 mm between 6 o'clock and 12 o'clock sides	
	Casing diameter	φ17.1 mm	
	Height	2.8 mm	
Time indication		4 hands (with date hand)	4 hands (with day hand)
Driving system		Step motor (Load compensated driving pulse type)	
Additional mechanism		Date calendar by date hand	Numerical date calendar
		—	Day calendar by day hand
		Instant calendar (date) setting device	Instant calendar (day and date) setting device
		Train wheel setting device	
		Electronic circuit reset switch	
Loss/gain		Monthly rate at normal temperature range: less than 15 seconds	
Regulation system		Nil	
Measuring gate by quartz tester		Use 10-second gate.	
Battery		SEIKO SR621SW, Maxell SR621SW, SONY SR621SW, EVEREADY 364 Battery life is approximately 2 years. Voltage: 1.55V	
Jewels		1 jewel	

HATTORI SEIKO CO., LTD.

PARTS CATALOGUE

Cal. 4K25A

Disassembling procedures Figs.: ① → ④⑩

Reassembling procedures Figs.: ④⑩ → ①

Lubricating: Types of oil

● Moebius A

○ SEIKO Watch Oil S-6

Oil quantity

○ Normal quantity

○ Extremely small

○ ⇨ Please see the remarks on the following pages.

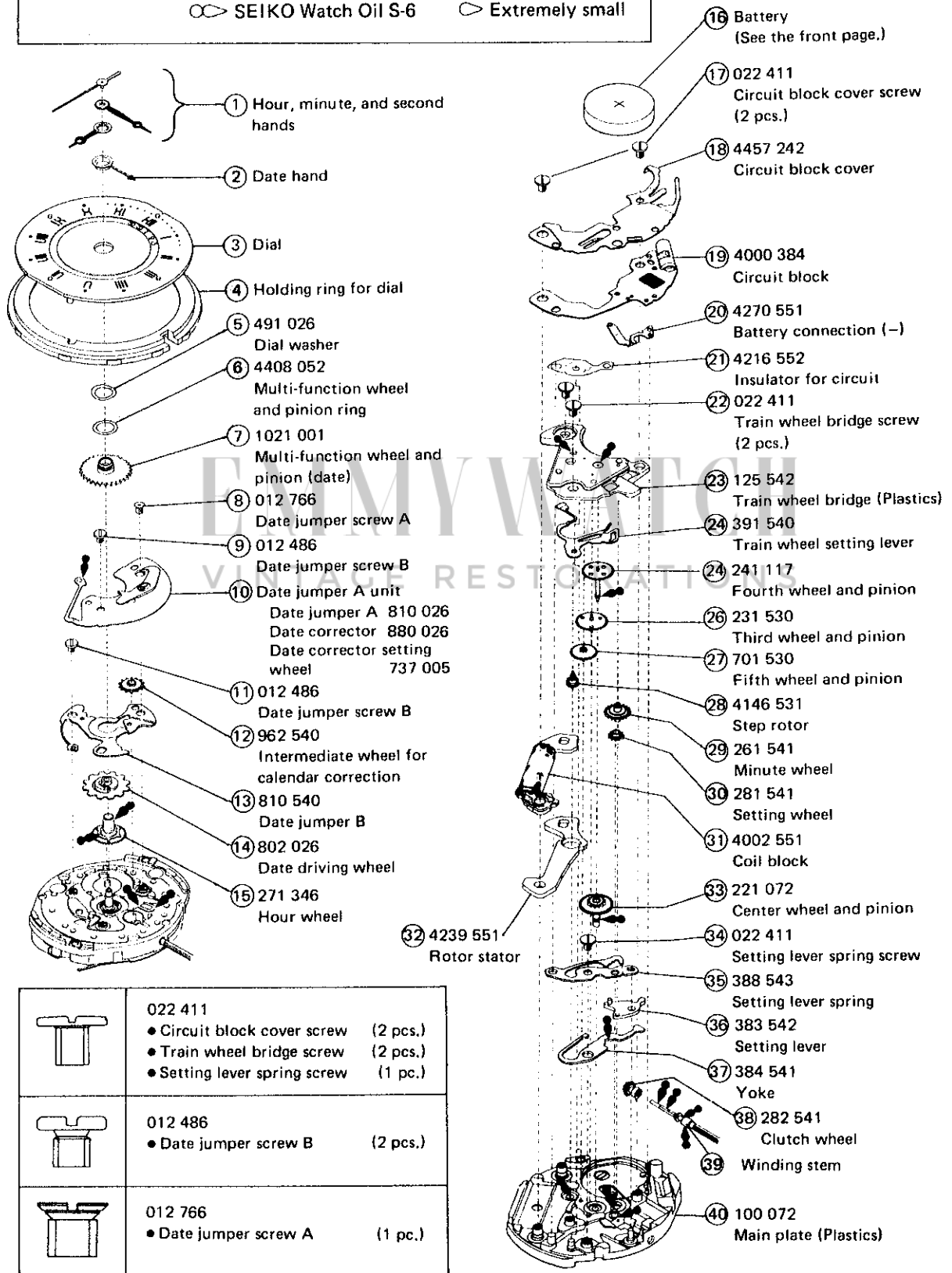

	022 411 ● Circuit block cover screw (2 pcs.) ● Train wheel bridge screw (2 pcs.) ● Setting lever spring screw (1 pc.)
	012 486 ● Date jumper screw B (2 pcs.)
	012 766 ● Date jumper screw A (1 pc.)

Remarks:

④ Holding ring for dial 884 155

③⑨ Winding stem 351 546

The types of these parts are determined based on the design of cases.

Refer to "SEIKO Casing Parts Catalogue" to choose corresponding parts.

⑥ Multi-function wheel and pinion ring 4408 052

Use of multi-function wheel and pinion ring depends on individual movements. If the ring is not included in a movement, therefore, it is not necessary to install one.

TECHNICAL GUIDE

- The explanation here is only for the particular points of Cal. 4K25A.
- For the repairing, checking and measuring procedures, refer to the "TECHNICAL GUIDE, GENERAL INSTRUCTIONS".

I. STRUCTURE OF THE CIRCUIT BLOCK

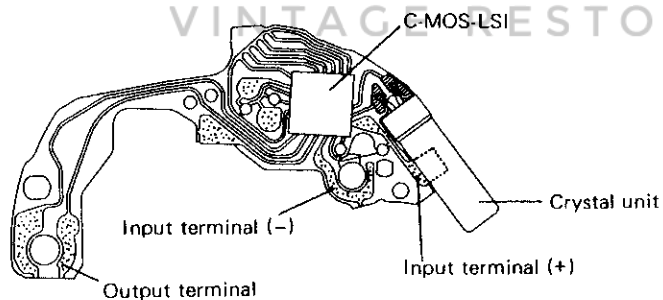

II. REMARKS ON DISASSEMBLING AND REASSEMBLING

Use the universal movement holder for disassembling and reassembling.

② Date hand

• **How to install**

Place the movement directly on a flat metal plate or the like to install the hand.

Install the date hand with care not to press excessively, since its setting angle is determined by the step portion of the multi-function wheel and pinion (date).

- 1) Press in the date hand with its tip on a desired date index on the dial.
 - * Perform the pressing-in job by seeing with a single loupe or a microscope.
 - * Even if the date hand is set into position, it appears unseated, compared with the hour and minute hands, but this is not an irregularity.
 - * Be careful not to press in the date hand excessively, since overpressure may damage the main plate.

- 2) Pull out the crown to the second click (time setting position).
- 3) Turn the crown clockwise until the date hand's shift to the next date is completed. (In this case, 12 o'clock is midnight.)
- 4) Install the hour and minute hands at the 12 o'clock position.

Step portion of the multi-function wheel and pinion (date)

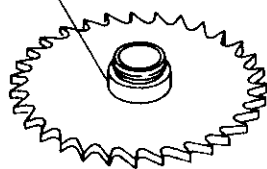

Multi-function wheel and pinion (date)

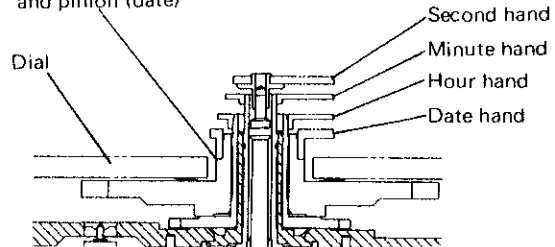

Installing the date hand → Shift of the date hand to the next date → Installing the hour and minute hands

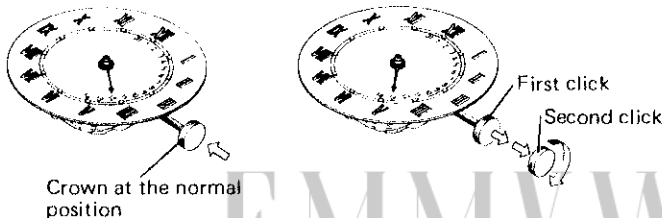

EMMY WATCH
VINTAGE RESTORATIONS

⑩ Date jumper A unit

Date jumper A unit consists of date corrector, date jumper A and date corrector setting wheel. Since a plastic date corrector is used, follow the procedures below in disassembling and reassembling. However, do not disassemble the date jumper A unit except when replacing the parts.

• How to disassemble

- (1) Loosen the date jumper screws A and B to remove the whole of the date jumper A unit.
- (2) Place the date jumper A unit on two flat metal plates placed side by side, with the date corrector side up, in the manner that the date corrector setting wheel lies between the plates.
- (3) Lightly press the date corrector setting wheel's axle head with a tip of tweezers.

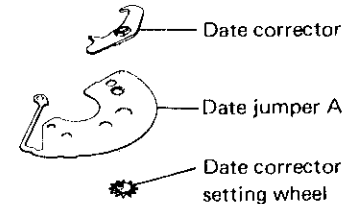
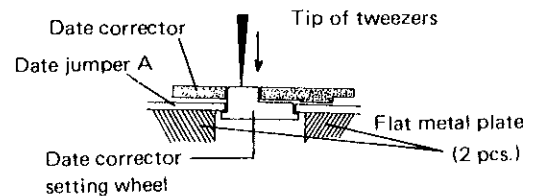

• How to reassemble

- (1) Install the date corrector setting wheel and date jumper A individually onto the movement.
- (2) Tighten the date jumper screws A and B.
- (3) Set the date corrector on the date corrector setting wheel's axle head. Then, lightly press the date corrector around the contact with the date corrector setting wheel's axle head.

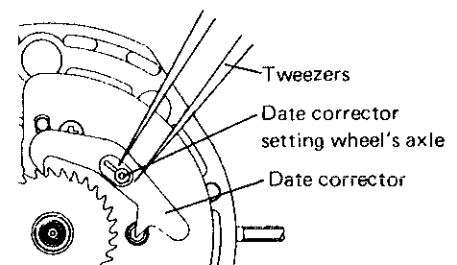

- **Setting position**

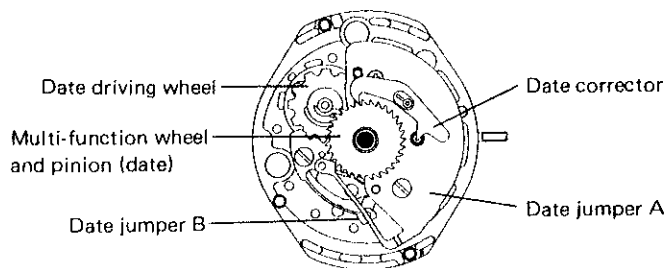

⑩ **Battery**

- **How to install**

Make sure that the plus lead terminal portion of the circuit block cover touches the side surface of the battery.

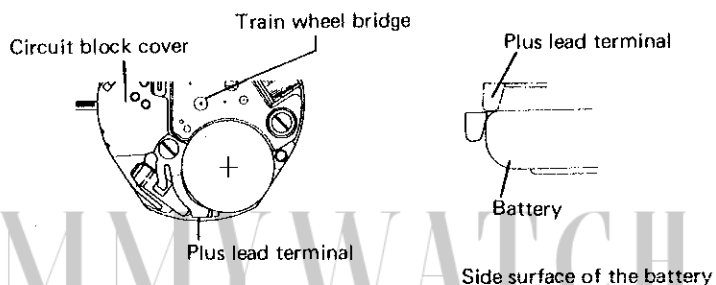

EMMYWATCH
VINTAGE RESTORATIONS

⑬ **Train wheel bridge**

- **Setting position**

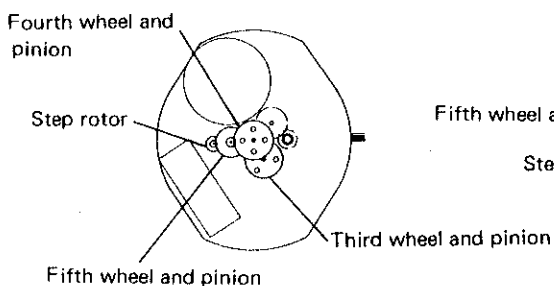

- **Cleaning**

Use Daiflon S-3 for cleaning.

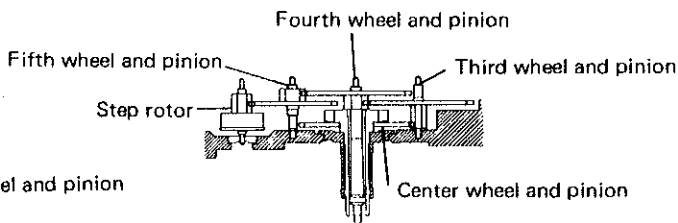

⑭ **Train wheel setting lever**

- **Setting position and Lubricating**

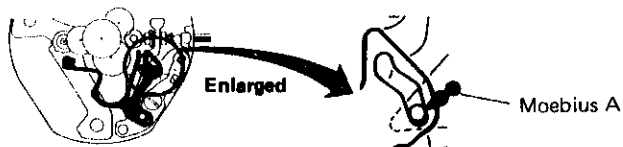

③① Setting wheel

● Installing

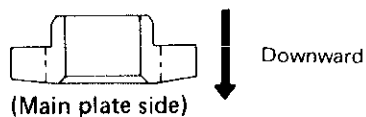
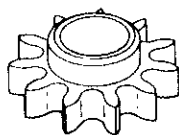

③③ Center wheel and pinion

● Lubricating

See the illustration on the right.

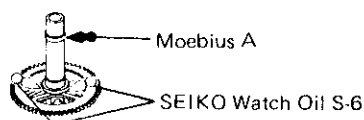

III. VALUE CHECKING

● Coil block resistance

2.7K Ω ~ 4.1K Ω

● Current consumption

For the whole of the movement : less than 1.4 μ A

For the circuit block alone : less than 0.4 μ A

EMMY WATCH
VINTAGE RESTORATIONS

Remarks:

- When the current consumption exceeds the standard value for the whole of the movement but less than the standard value for the circuit block alone, overhaul and clean the movement parts and then measure current consumption for the whole of the movement again. The driving pulse generated to compensate a heavy load that may apply on the gear train, etc. is considered to cause excessive current consumption for the whole of the movement.

PARTS CATALOGUE

Cal. 4K26A

Disassembling procedures Figs.: ① → ③⑨
 Reassembling procedures Figs.: ③⑨ → ①
Lubricating: Types of oil
 ● Moebius A
 ○ SEIKO Watch Oil S-6
Oil quantity
 ○ Normal quantity
 ◊ Extremely small

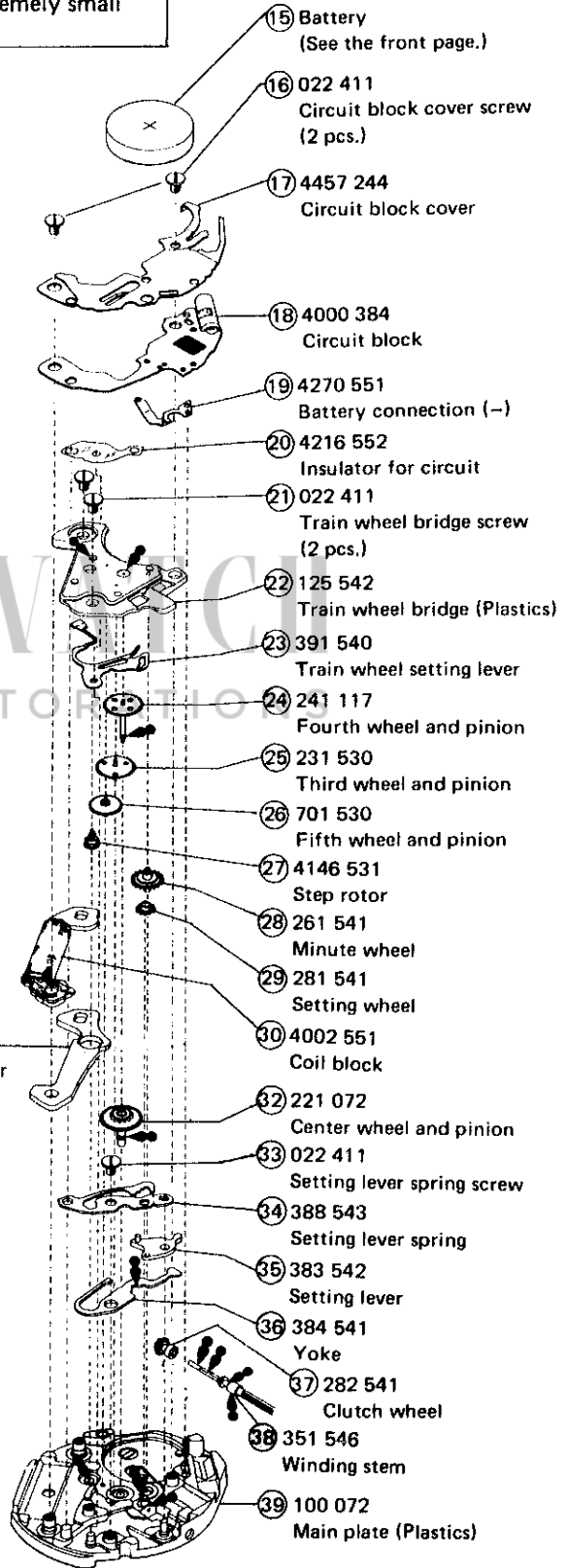
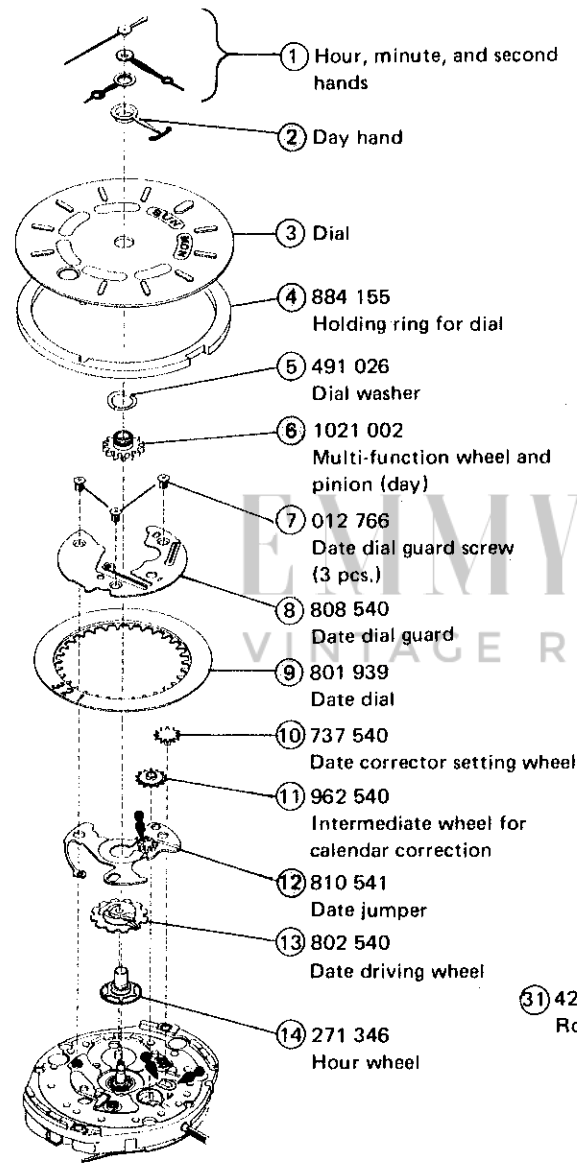

	022 411 ● Circuit block cover screw (2 pcs.) ● Train wheel bridge screw (2 pcs.) ● Setting lever spring screw (1 pc.)
	012 766 ● Date dial guard screw (3 pcs.)

○ ⇨ Please see the remarks on the following pages.

Remarks:

④ Holding ring for dial 884 155

③⑧ Winding stem 351 546

The types of these parts are determined based on the design of cases.

Refer to "SEIKO Casing Parts Catalogue" to choose corresponding parts.

⑨ Date dial

Parts No.	Crown position	Calendar frame position	Figure color	Background color
801 939	3 o'clock	6 o'clock	Black	White

The type of date dial is determined based on the design of cases. For details, refer to "SEIKO Casing Parts Catalogue". If any other type of date dial is required, please specify (1) Cal. No., (2) the crown position, (3) the calendar frame position, (4) Dial No. and (5) the color.

TECHNICAL GUIDE

- The explanation here is only for the particular points of Cal. 4K26A.
- For other repairing, checking and measuring procedures of Cal. 4K26A, refer to the "TECHNICAL GUIDE" for Cal. 4K25A on pages 3 ~ 6.

I. REMARKS ON DISASSEMBLING AND REASSEMBLING

Use the universal movement holder for disassembling and reassembling.

② Day hand

• **How to install**

Place the day hand directly on a flat metal plate or the like to install the day hand.

- 1) Pull out the crown to the second click (time setting position).
- 2) Turn the crown clockwise until the multi-function wheel and pinion (day) turns two steps, and then push in the crown to the normal position. (Each two steps represent one day.)
- 3) Press in the day hand with its tip on a desired day index on the dial.

- * Be careful not to press in the day hand excessively, since overpressure may damage the main plate.
- * The day hand is designed to advance one day in two steps until about 4:00 A.M. Install the day hand so that it points to the center of the day index when having moved two steps.

[For Reference]

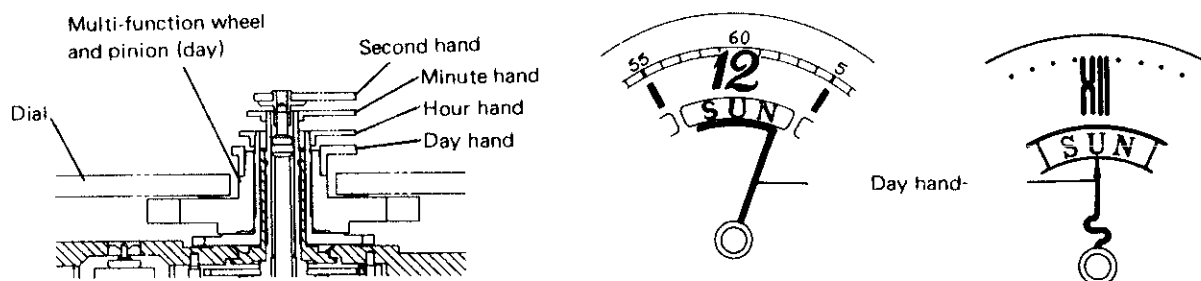

⑥ Multi-function wheel and pinion (day)

- Setting position

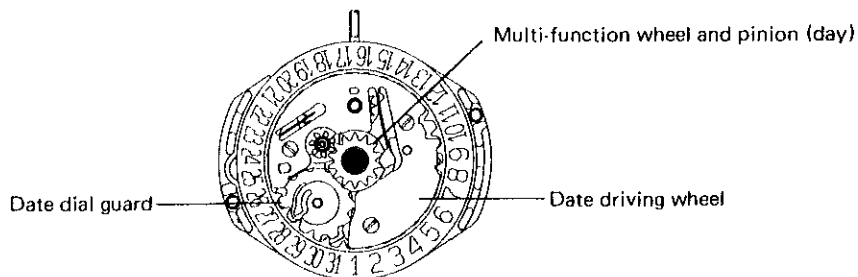

⑫ Date jumper

In installing the date jumper on the main plate at the part "A", you may find that the guide hole of the date jumper is tight for the guide pin of the main plate. In that case, push the part "A" with tweezers to set the date jumper in position.

- Lubrication

