



EMMYWATCH

VINTAGE RESTORATIONS

Seiko 2A27A Movement Parts (1)

Compiled by EmmyWatch - <https://www.emmywatch.com>

I. SPECIFICATIONS

Cal. No.		2A27A
Item		
Time indication		2 hands
Additional mechanism		<ul style="list-style-type: none"> • Train wheel setting device • Electronic circuit reset switch
Loss/gain		Monthly rate at normal temperature range: less than 15 seconds
Movement size	Outside diameter	ϕ 18.3 mm (16.3 mm between 3 o'clock and 9 o'clock sides)
	Casing diameter	ϕ 17.6 mm
	Height	2.3 mm without battery
Regulation system		Trimmer condenser
Measuring gate by quartz tester		Any gate is available.
Battery		SEIKO (SEIZAIKEN) TR621SW, Maxell SR621SW, SONY EVEREADY 364 Battery life is approximately 2 years. Voltage: 1.55V
Jewels		2 jewels

II. DISASSEMBLING, REASSEMBLING, AND LUBRICATING OF THE CASE

Disassembling procedures Figs.: ① → ⑩

Reassembling procedures Figs.: ⑩ → ①

Lubricating: Silicone grease 500,000 c.s.

∞ Normal quantity ⊗ No lubricating

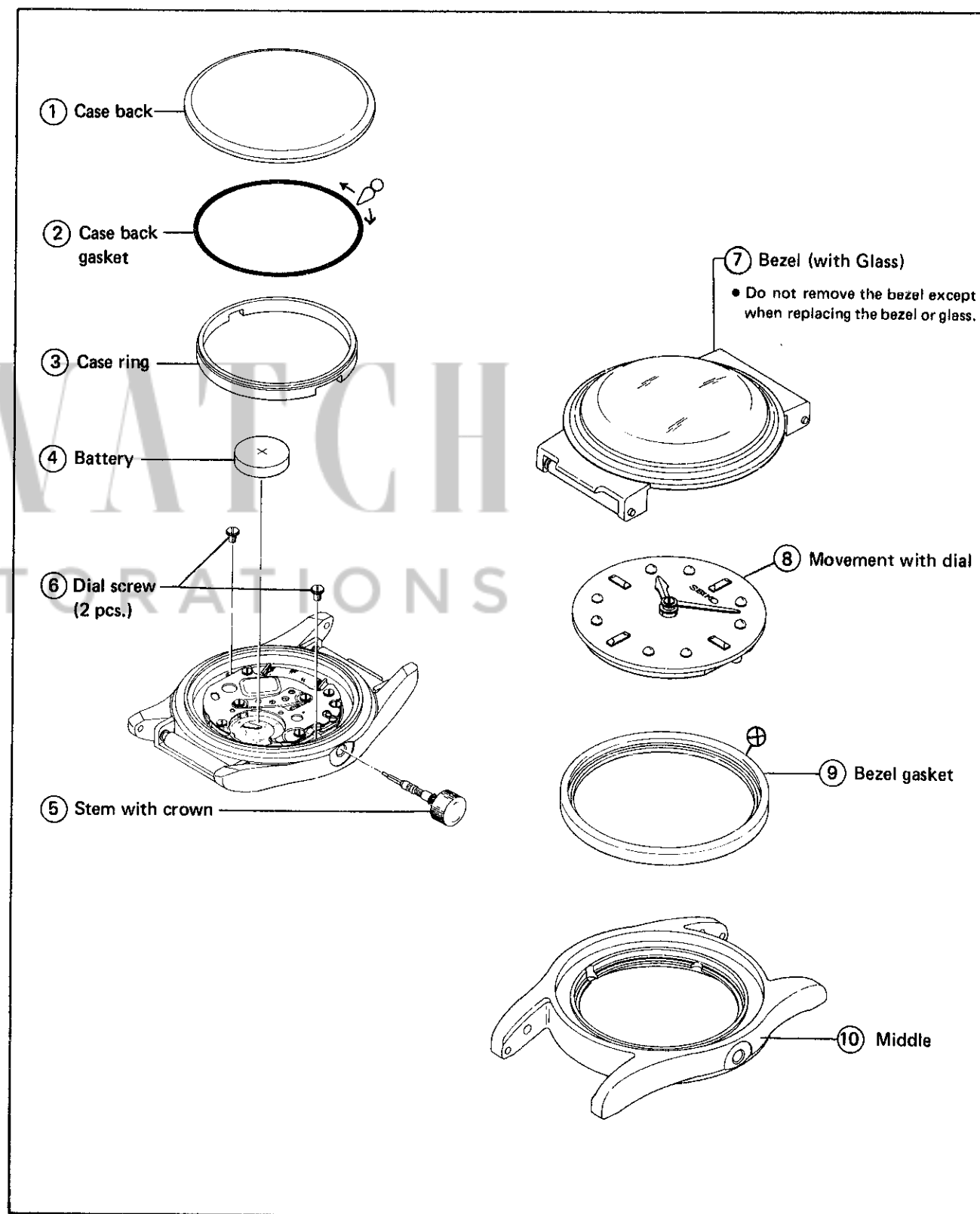

Remarks on disassembling and reassembling

③ Case ring

Reassembling

The case ring is notched at two places. Set it with its broader notch at the stem side.

④ Stem with crown

Disassembling

With the crown pulled out to the 1st click position, remove the stem while pushing the tip of the setting lever downward through the notch of the circuit block cover.

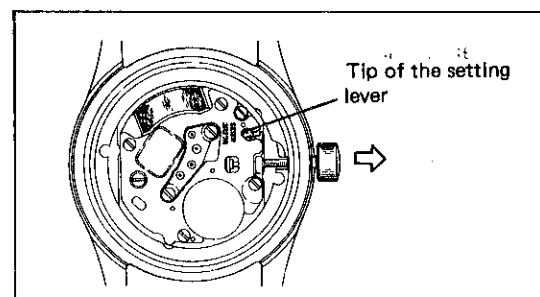

⑨ Bezel gasket

Reassembling

There are two kinds of bezel gaskets according to the case number. Make sure to install the appropriate one.

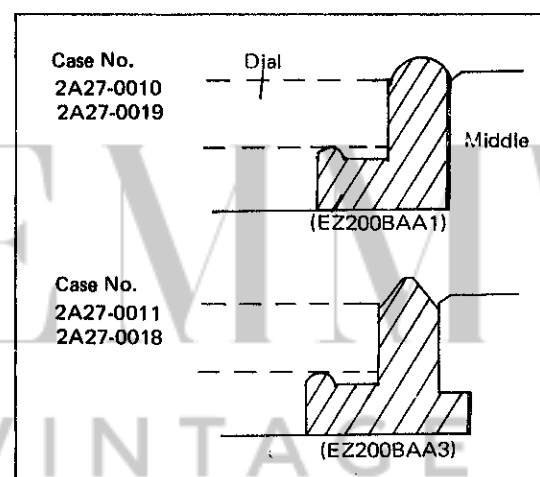

● Glass and glass gasket

(Do not disassemble the glass and the glass gasket except when replacing them.)

Disassembling

1. Remove the bezel with glass from the middle.
2. Push the glass from inside with fingers. If the glass cannot be removed by pushing with fingers, use the tempered glass inserting tool and squeeze the glass.
Note: If there is left any glass sludge on the bezel, clean it with a brush.

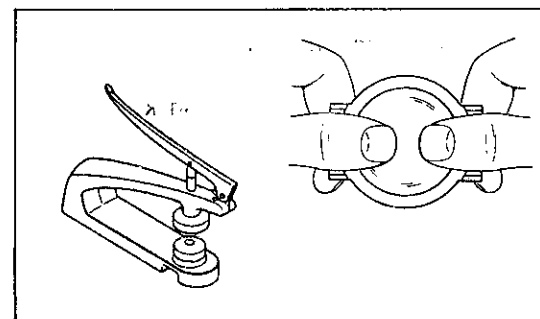

3. Remove the glass gasket.

Reassembling

1. Set the glass gasket to the bezel.
Note: Do not lubricate the glass gasket.
2. Use a tempered glass inserting tool to squeeze the glass for reassembling.
3. Set the bezel with glass to the middle.

● Hands

Disassembling

Loosen the minute hand screw while holding the minute hand lightly with fingers, and remove it. The hour hand is tightly installed. Place a vinyl sheet on the dial so as not to scratch its surface and gradually pry the hour hand up with a bow-type hand remover or pliers.

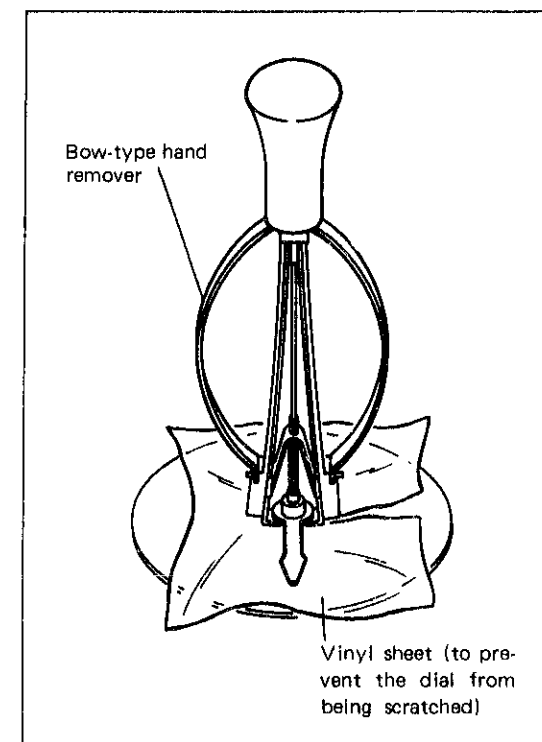

Reassembling

1. Place the edges of the cannon pinion to which the hour hand is fixed in line with the 6 o'clock and 12 o'clock positions as shown in the illustration a. on the right, and install the hour hand at the 12 o'clock position.
2. Turn the hour hand counterclockwise once and then advance it clockwise to the 12 o'clock position.
3. Install the minute hand at the 12 o'clock position so that it is exactly lined up with the hour hand as shown in the illustration b. on the right. Make sure that the pivot of the minute hand firmly catches the square edges of the cannon pinion.
4. Then, set the minute hand screw and fasten it.

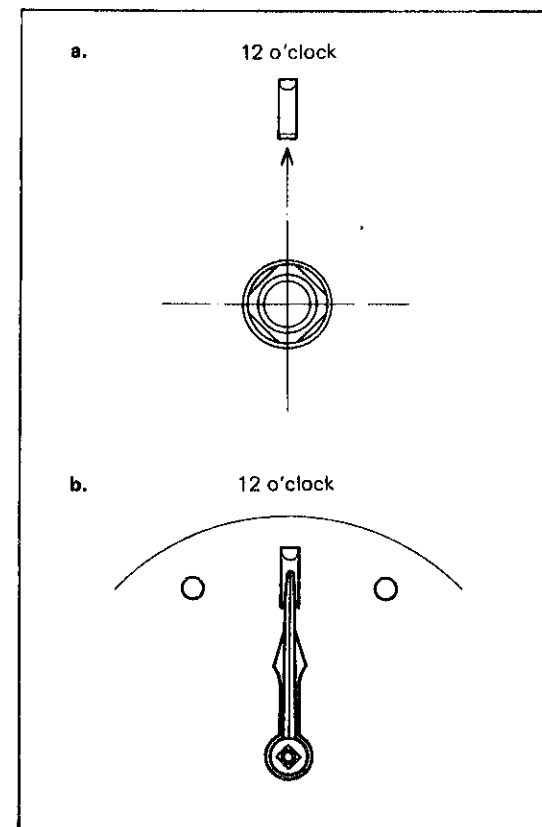

III. CHECKING AND ADJUSTMENT

- The explanation here is only for the particular points of Cal. 2A27A.
Refer to the "TECHNICAL GUIDE, SEIKO ANALOGUE QUARTZ, Cal. 2A22A, 2A23A, 2A29A and 2A32A" and the "TECHNICAL GUIDE, GENERAL INSTRUCTION" for SEIKO Analogue Quartz for details.

Procedure	
CHECK COIL BLOCK	<p>Result: Normal: 2.3KΩ ~ 2.8KΩ</p> <p>Defective— — Less than 2.3KΩ — (Short circuit) — More than 2.8KΩ — (Broken wire)</p>
CHECK CURRENT CONSUMPTION	<ul style="list-style-type: none">• Check current consumption for the whole of the movement. <p>Result: Normal: Less than 1.1μA Defective: More than 1.1μA</p> <p>* How to find defects when the current consumption is more than 1.1μA. Check current consumption with the crown at the 1st click position.</p> <p>Result: Normal (Circuit block): Less than 0.6μA Check the gear train mechanism. Defective (Circuit block): More than 0.6μA Replace the circuit block with a new one.</p>

All procedures of Disassembling, Reassembling, Lubricating, Checking and Adjustment are completed.