



# EMMYWATCH

VINTAGE RESTORATIONS

Seiko 2A22A,2A23A,2A29A,2A32A Movement Parts (1)

*Compiled by EmmyWatch - <https://www.emmywatch.com>*

# TECHNICAL GUIDE

## SEIKO QUARTZ

CAL. 2A22A  
CAL. 2A23A  
CAL. 2A29A  
CAL. 2A32A

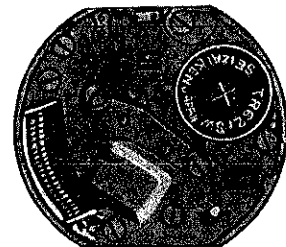
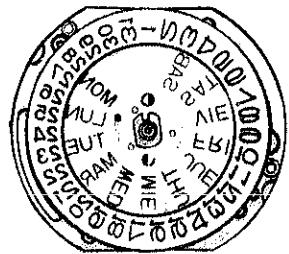

### CONTENTS

I. SPECIFICATIONS .....	1
II. STRUCTURE OF THE CIRCUIT BLOCK .....	1
III. DISASSEMBLING, REASSEMBLING, AND LUBRICATING .....	2
1. Hour, minute, and second hands ~ Holding ring for dial .....	2
2. Battery ~ Crystal oscillator spacer .....	3
3. Train wheel bridge screw ~ Stem with crown .....	4
4. Snap for day star with dial disk ~ Clutch wheel .....	5
IV. CHECKING AND ADJUSTMENT .....	6
• Check output signal .....	6
• Check battery voltage .....	6
• Check battery conductivity .....	6
• Check conductivity of circuit block .....	6
• Check coil block .....	6
• Check gear train mechanism .....	6
• Check setting mechanism .....	7
• Check reset and train wheel setting condition .....	7
• Check current consumption .....	8
• Check accuracy .....	8
• Check battery life indicator .....	8
• Check water resistance .....	8
• Check appearance and functioning .....	8
V. DISASSEMBLING AND REASSEMBLING OF THE CASE FOR Cal. 2A22A DIVER'S WATCH .....	9

## I. SPECIFICATIONS

Item	Cal. No.	2A22A	2A23A	2A29A	2A32A
Time indication		3 hands		2 hands	3 hands
Additional mechanism	Date				
		-	Day of the week	-	-
	Instant date setting device				
		-	Instant day setting device	-	-
	Train wheel setting device				
	Electronic circuit reset switch				
	Battery life indicator		-		Battery life indicator
Loss/gain		Monthly rate at normal temperature range: less than 15 seconds			
Movement size	Outside diameter	φ18.3 mm 16.3 mm between 3 o'clock and 9 o'clock sides		φ20.7 mm	
	Casing diameter	φ17.6 mm		φ20.0 mm	
	Height (without battery)	2.3 mm	2.7 mm	2.3 mm	2.5 mm
Regulation system		Trimmer condenser			
Measuring gate by quartz tester		Any gate is available.			
Battery		SEIKO (SEIZAIKEN) TR621SW, Maxell SR621SW, SONY EVEREADY 364 Battery life is approximately 2.5 years. Voltage: 1.55V			
Jewels		2 jewels			

## II. STRUCTURE OF THE CIRCUIT BLOCK

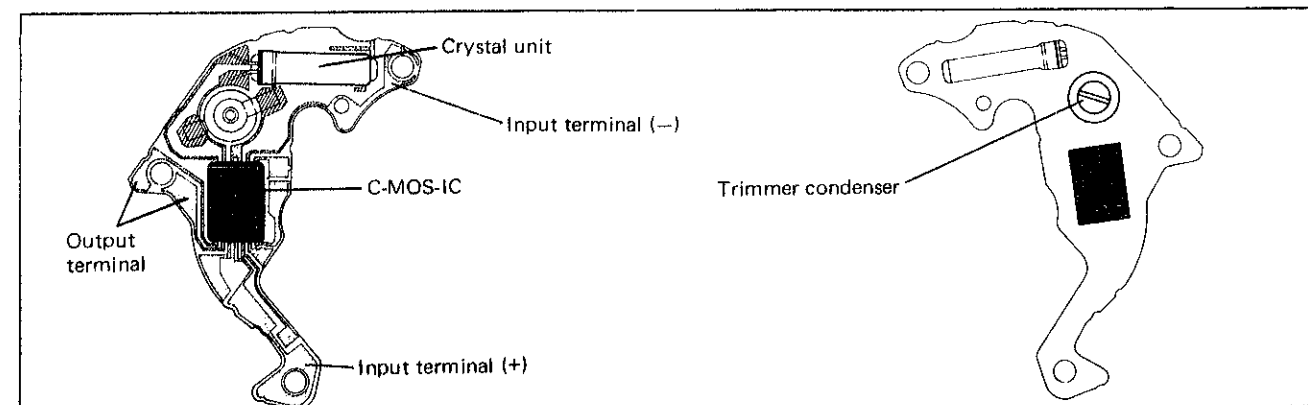

## III. DISASSEMBLING, REASSEMBLING, AND LUBRICATING

Disassembling procedures Figs.: ① → ④④

Reassembling procedures Figs.: ④④ → ①

**Lubricating:**

<b>Types of oil</b>	<b>Oil quantity</b>
∞ Moebius A	∞ Normal
● SEIKO Watch Oil S-6	∞ Extremely small

### 1. Hour, minute, and second hands ~ Holding ring for dial

Ex. Cal. 2A23A

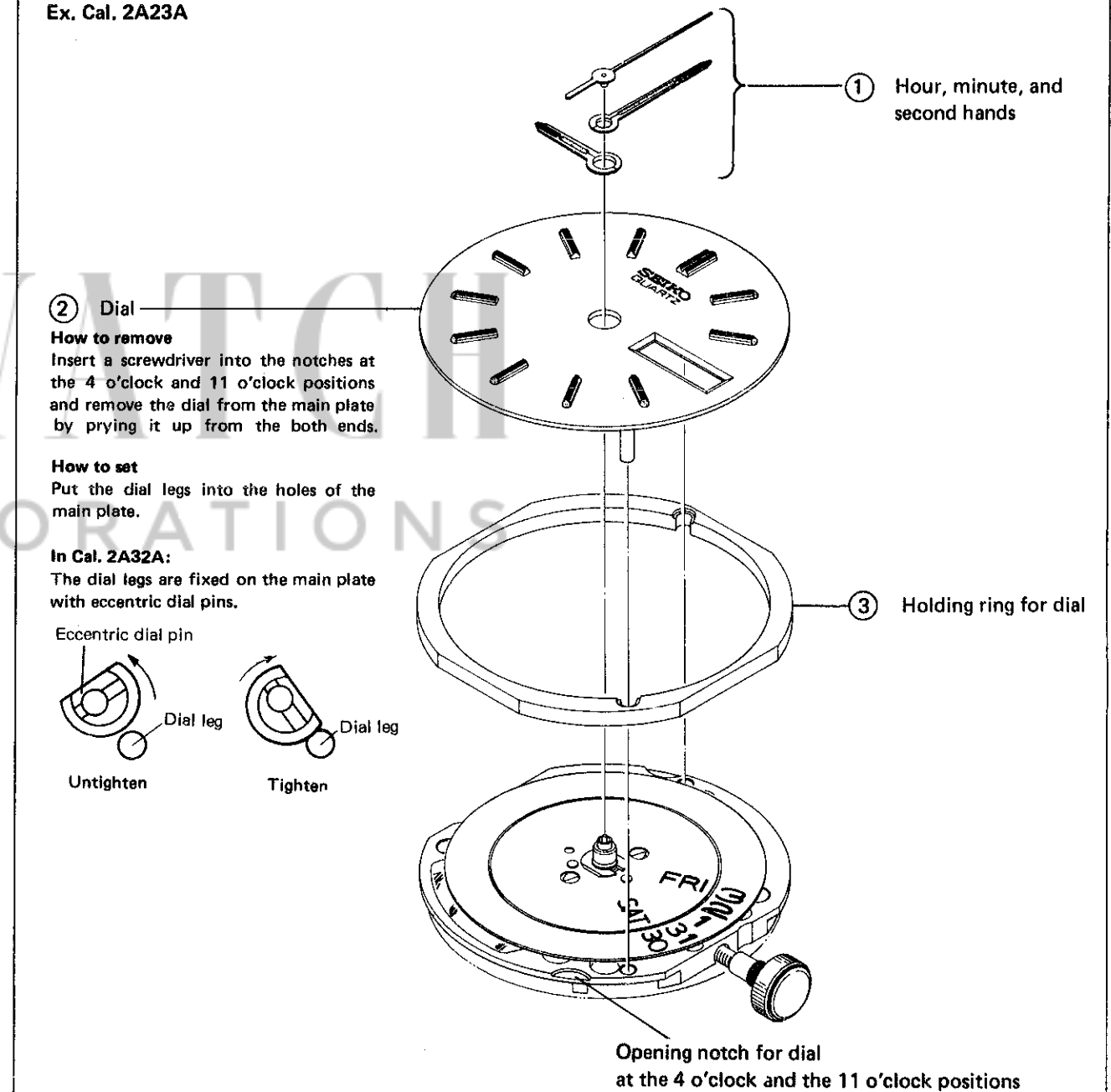

List of the screws used

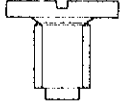
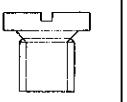
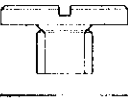
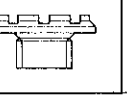
Shape	Part No.	Name	Shape	Part No.	Name
	012 005	Train wheel bridge screw Screw for circuit block cover Setting lever spring screw		012 006	Date dial guard screw A
	012 008	Date driving wheel screw		012 007	Date dial guard screw B

2. Battery ~ Crystal oscillator spacer

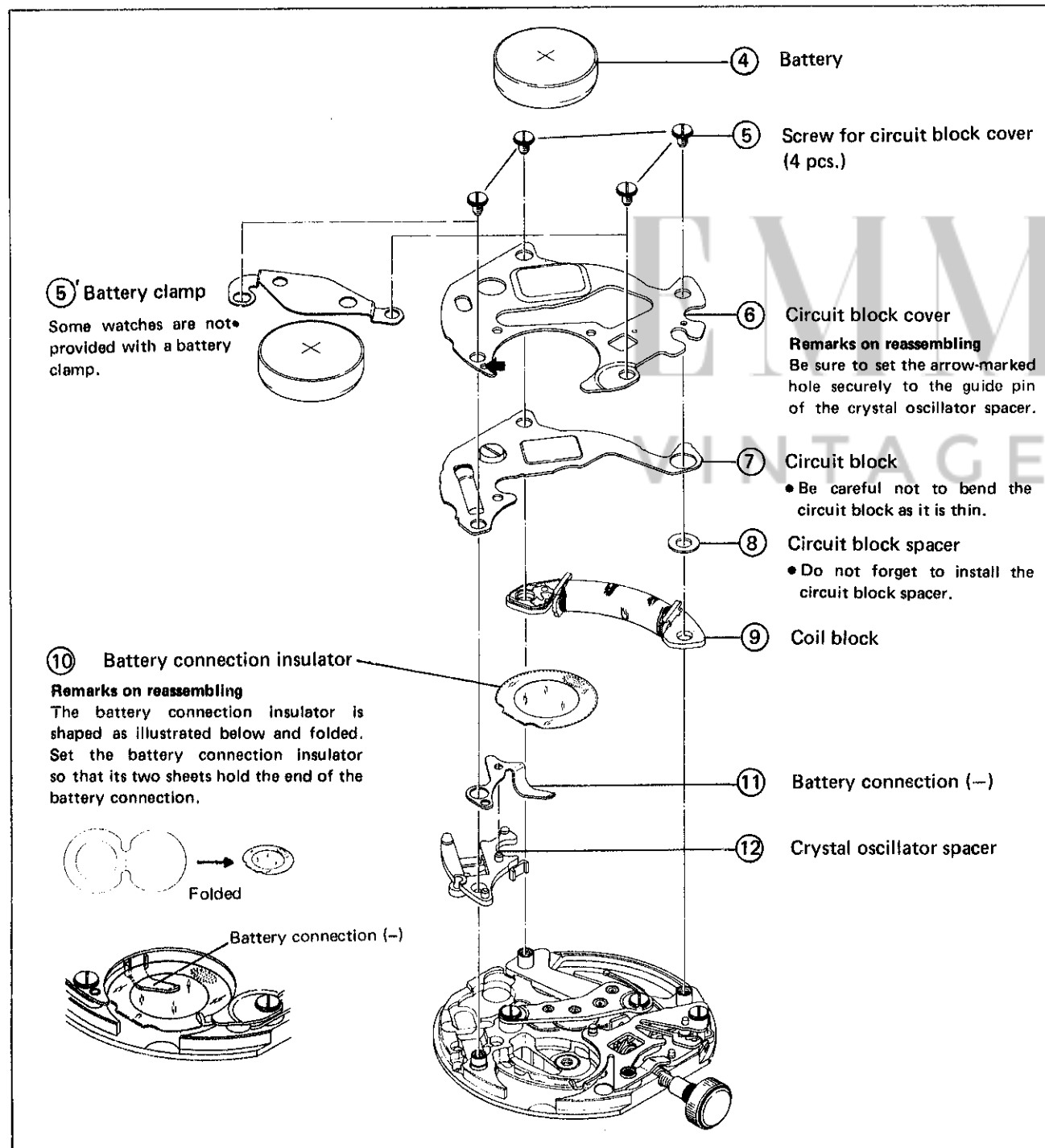

3. Train wheel bridge screw ~ Stem switch crown

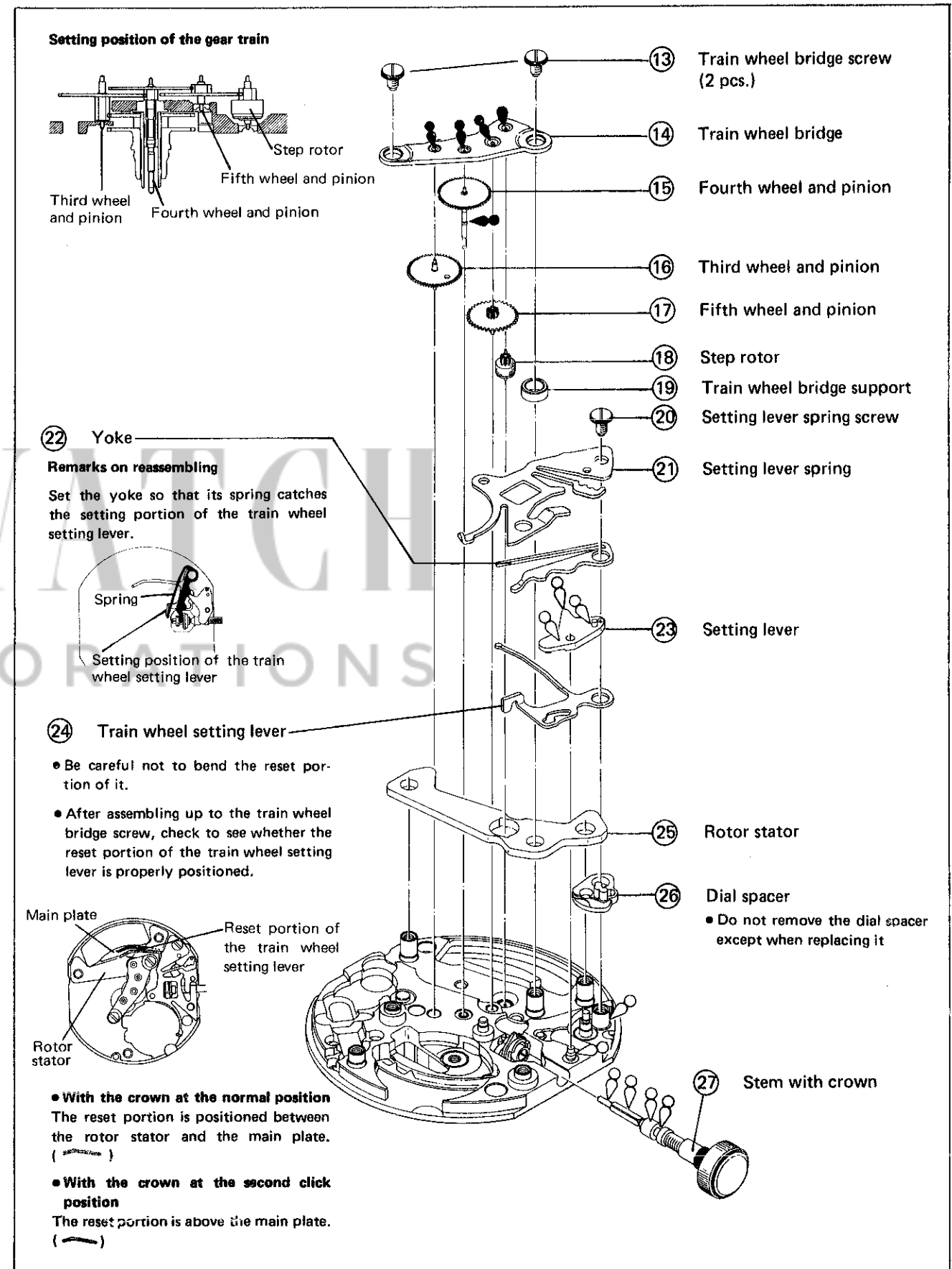

4. Snap for day star with dial disk ~ Clutch wheel

28 Snap for day star with dial disk

Remarks on reassembling  
Press it in as shown in the illustration.

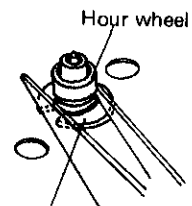

Snap for day star with dial disk

32 Date dial guard (with day corrector)

Remarks on reassembling  
Set the date dial guard so that its spring is properly engaged with the date jumper.

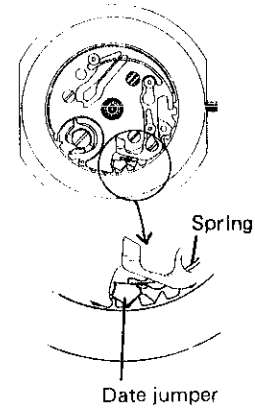

Date jumper

44 Clutch wheel (with clutch wheel guard)

The clutch wheel has a clutch wheel guard. Do not remove the clutch wheel guard except when replacing it. When setting or removing it, be sure to pass a stick through the clutch wheel so that it may not turn while the work.

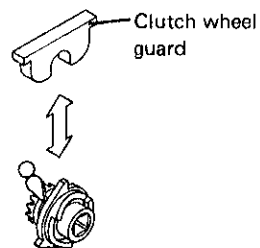

Clutch wheel guard

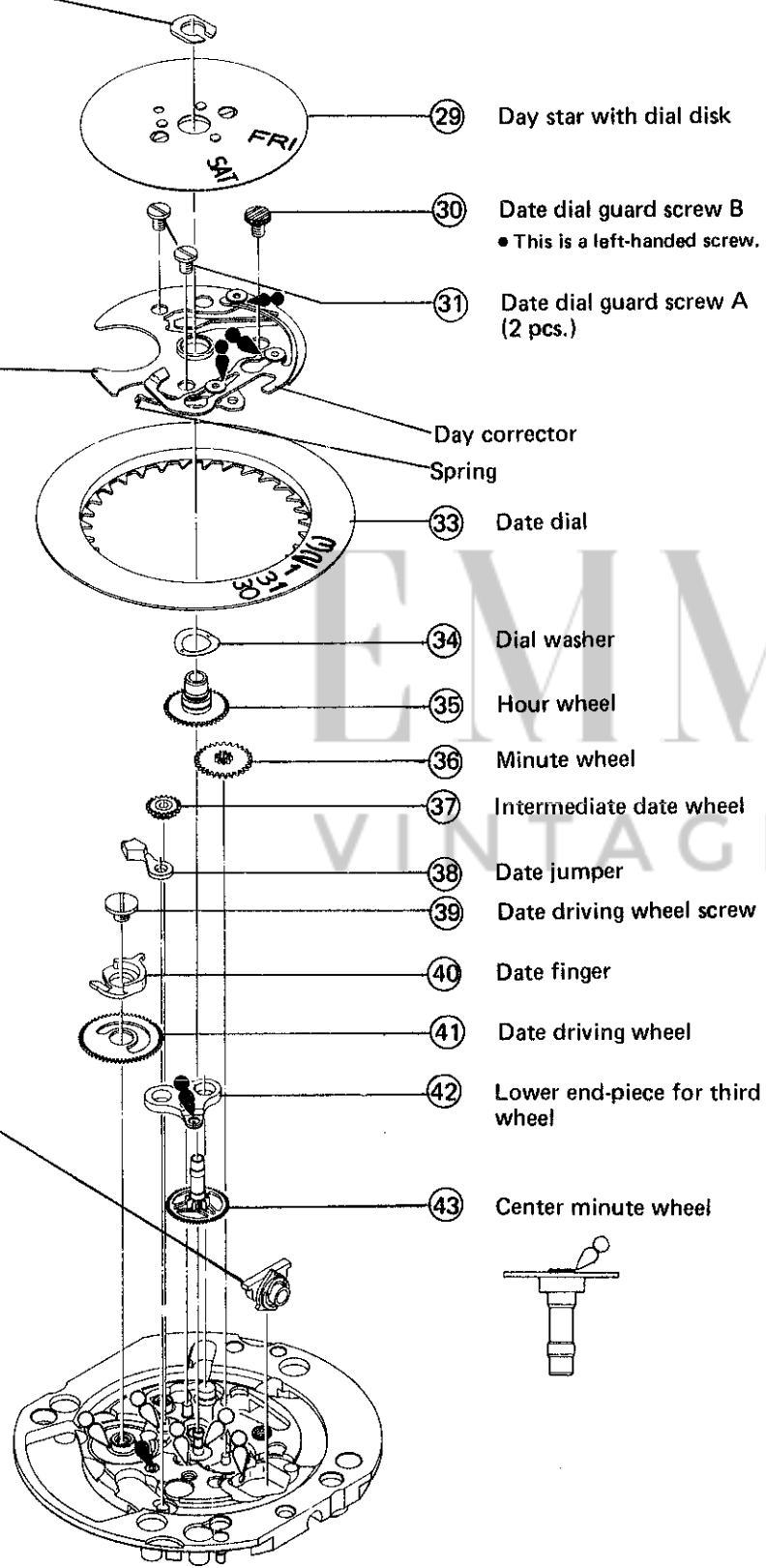

IV. CHECKING AND ADJUSTMENT

- The explanation here is only for the particular points of Cals. 2A22A, 2A23A, 2A29A and 2A32A. Refer to the "TECHNICAL GUIDE, GENERAL INSTRUCTION" for SEIKO Analogue Quartz for details.

Procedure	
<b>CHECK OUTPUT SIGNAL</b>	<p><b>Result:</b> Normal: Input indicator blinks every second. Defective: Input indicator does not blink every second.</p>
<b>CHECK BATTERY VOLTAGE</b>	<p>Use the volt-ohm-meter. Range to be used: DC 3V</p> <p><b>Result:</b> Normal: More than 1.5V Defective: Less than 1.5V Replace the battery with a new one.</p>
<b>CHECK BATTERY CONDUCTIVITY</b>	<p>Check to see if the battery voltage is transmitted to the circuit block.</p>
<b>CHECK CONDUCTIVITY OF CIRCUIT BLOCK</b>	<p>Check for any short circuit or defective conductivity of the conductive portions of the circuit block.</p>
<b>CHECK COIL BLOCK</b>	<p>Check for any broken wire or short circuit of the coil block. Use the volt-ohm-meter, and be sure to make a zero-ohm adjustment.</p> <p>Range to be used: OHMS x 100</p> <p><b>Result:</b> Normal: <math>2.8K\Omega \sim 3.4K\Omega</math> Defective: Less than <math>2.8K\Omega</math> (Short circuit) More than <math>3.4K\Omega</math> (Broken wire) Replace the coil block with a new one.</p>
<b>CHECK GEAR TRAIN MECHANISM</b>	<p>Check alignment and play in the step rotor and in the wheels, and also check to see whether the gear train is contaminated with dust or lint and whether it is properly lubricated.</p>



Procedure

CHECK SETTING MECHANISM

Check alignment and play in the wheels, and also check to see whether the setting mechanism is contaminated with dust or lint and whether it is properly lubricated.

CHECK RESET AND TRAIN WHEEL SETTING CONDITION

With the movement assembled, check to see whether the reset and train wheel setting condition is normal.

(1) Check train wheel setting condition.

Check the clearance between the train wheel setting lever and the fifth wheel and pinion.

• With the crown at the normal position

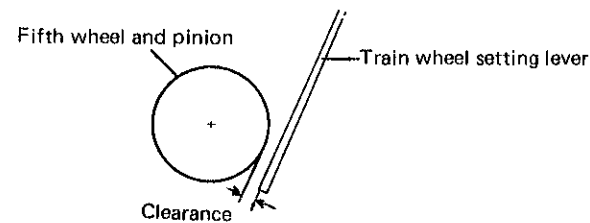

Result:
Normal: Clearance
Defective: No clearance
Replace the train wheel setting lever with a new one.

• With the crown at the second click position

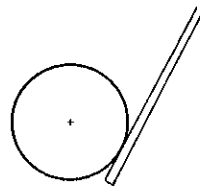

Result:
Normal: No clearance
Defective: Clearance
Replace the train wheel setting lever with a new one.

(2) Check reset condition.

Reset condition can be confirmed by checking output signal with a battery installed.

• With the crown at the normal position

Result:
Normal: Input indicator blinks every second.
Defective: Input indicator does not blink every second.
Replace the train wheel setting lever with a new one.

• With the crown at the second click position

Result:
Normal: Input indicator does not blink every second.
Defective: Input indicator blinks every second.
Replace the train wheel setting lever with a new one.

Procedure

CHECK CURRENT CONSUMPTION

- Do not check current consumption under an incandescent lamp since strong light may cause a watch to consume excess current.
Be sure to protect the movement from light with a black cloth, etc. while measuring.

Use the Digital Multi-Tester S-840A.

Set the A-V switch of the multi-adapter to the 'A' position and the mode switch of the tester to the 'uA'. The tester's value-averaging calculation function automatically takes average of a maximum and a minimum current consumption values.

Read the figure displayed after one minute to attain the averaged value.

Check current consumption for the whole of the movement.

Place the battery on the train wheel bridge, and then check current consumption.

Probe red . . . . . Battery connection (-)
Probe black . . . . . Battery (-) surface

Result:
Normal : Less than 1.0uA
Defective: More than 1.0uA

\*How to find defects when the current consumption is more than 1.0uA

Check current consumption for the circuit block alone with the crown at the second click position.

Result:
Normal (Circuit block): Less than 0.55uA
Check the gear train mechanism.
Defective (Circuit block): More than 0.55uA
Replace the circuit block with a new one.

CHECK ACCURACY

Use the electromagnetic detection microphone.

CHECK BATTERY LIFE INDICATOR

Check to see whether the second hand moves at 2-second intervals when the output voltage is set on 1.30V ~ 1.48V.

CHECK WATER RESISTANCE

CHECK APPEARANCE AND FUNCTIONING

## V. DISASSEMBLING AND REASSEMBLING OF THE CASE FOR CAL. 2A22A DIVER'S WATCH

Disassembling procedures Figs.: ① → ⑬

Reassembling procedures Figs.: ⑬ → ①

Lubricating:  Silicone grease (500,000 c.s.)

⊗ Do not lubricate

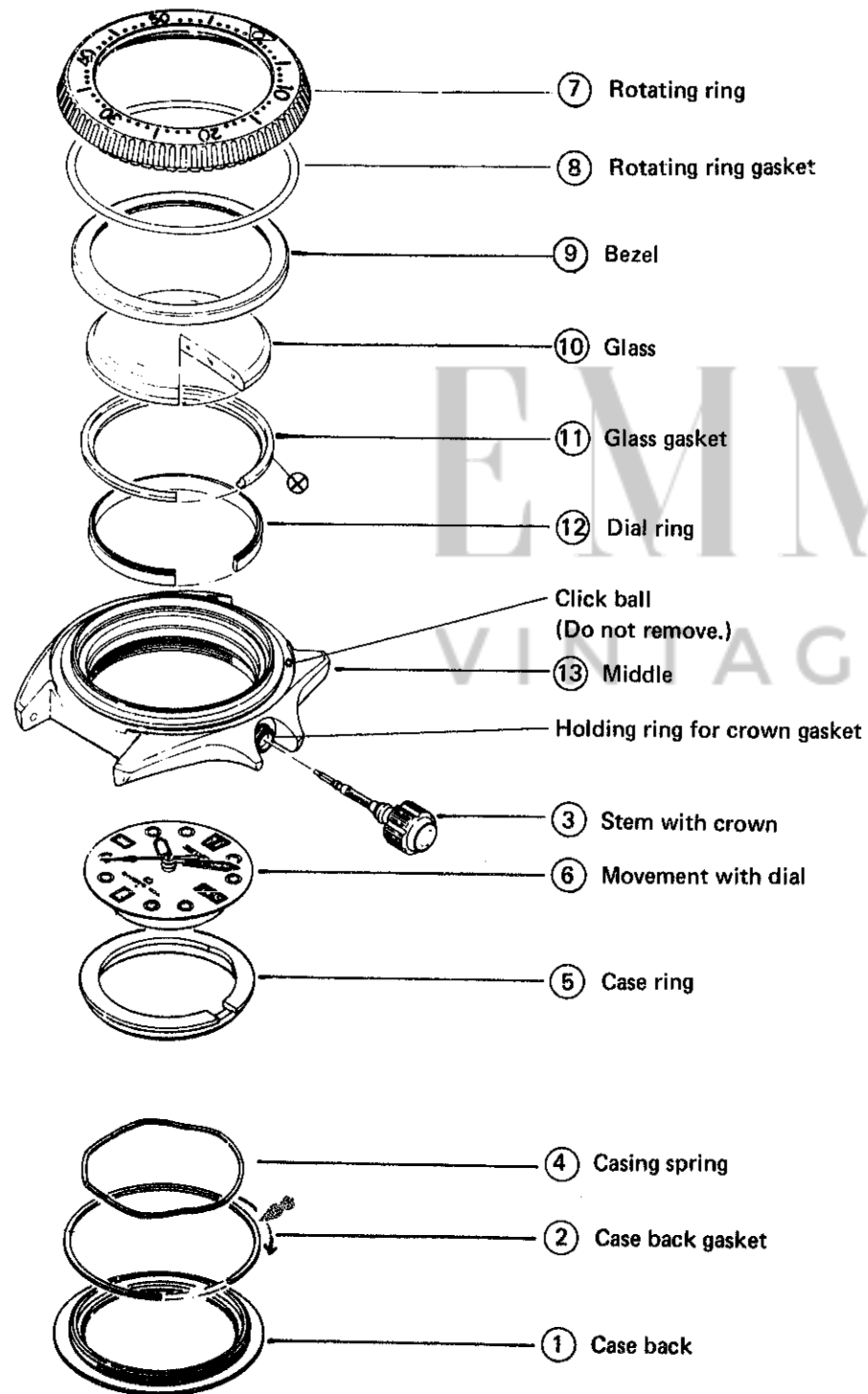

### Remarks on disassembling and reassembling

In view of the special requirements of a diver's watch, be sure to follow the notes below when the watch is repaired.

1. Dry the parts completely before reassembling and reassemble the watch in a room without dust and lint, and with low humidity.
2. Be sure to check that the hands move smoothly.
3. Be sure to check if there are any glass defect and loosened screws.
4. After repair, conduct a water resistance test.
5. Be sure to check that the strap is fixed to the middle correctly. (Push pin, buckle.)

### ⑦ Rotating ring

#### How to disassemble

Put the case opener into the opening notch of the rotating ring to remove.

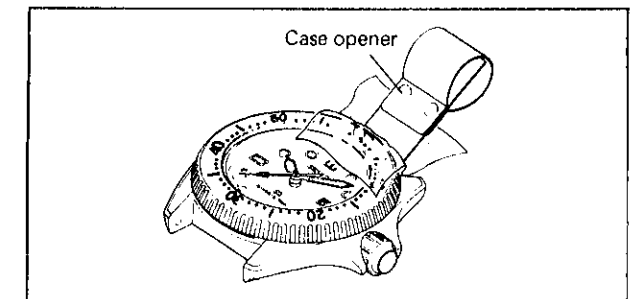

### ⑪ Glass gasket

#### How to reassemble

Make sure that the glass gasket is placed in position correctly. Check the place marked with a circle as shown in the illustration on the right.

Do not apply silicone grease (500,000 c.s.).

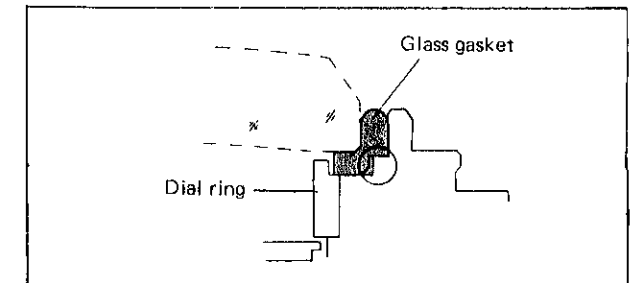

### ⑩ Glass

#### How to disassemble

After removing the bezel, push the glass from inside to remove. As the back surface of the glass is specially coated, remove the glass by pushing it with a fingercot or by using a chamois sheet so as not to scratch or stain the surface. If there is any stain, wipe it off with a soft, clean cloth. Clean dust and lint with a soft brush.

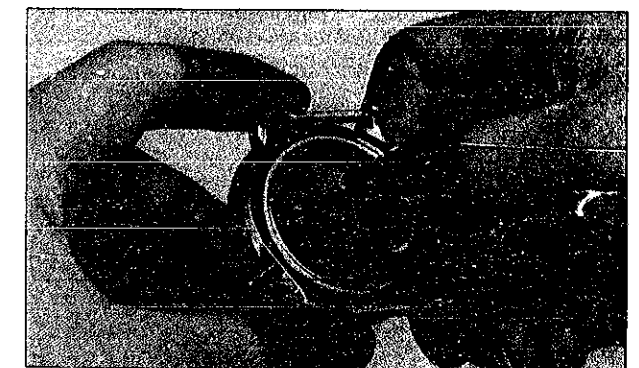

#### How to reassemble

Place the glass stably by pushing it on both ends directly from above. While pushing the glass, be sure that the glass gasket is placed in position correctly.

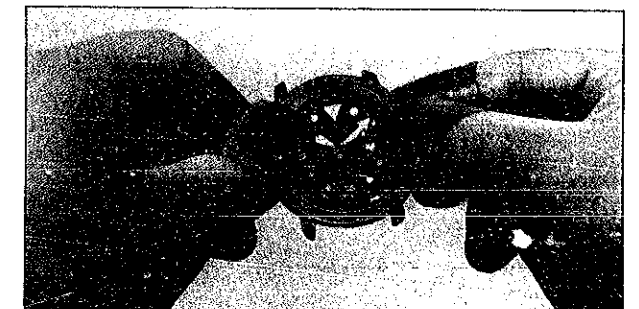

When replacing the crown gasket, follow the procedure below.

**How to disassemble the holding ring for crown gasket**

Squeeze the holding ring for crown gasket with pliers and remove it.

(Be sure to replace the holding ring for crown gasket with a new one.)

**How to reassemble the holding ring for crown gasket**

Be sure to apply silicone grease (500,000 c.s.) to the crown gasket.

Put a new holding ring for crown gasket in position with a finger or tweezers.

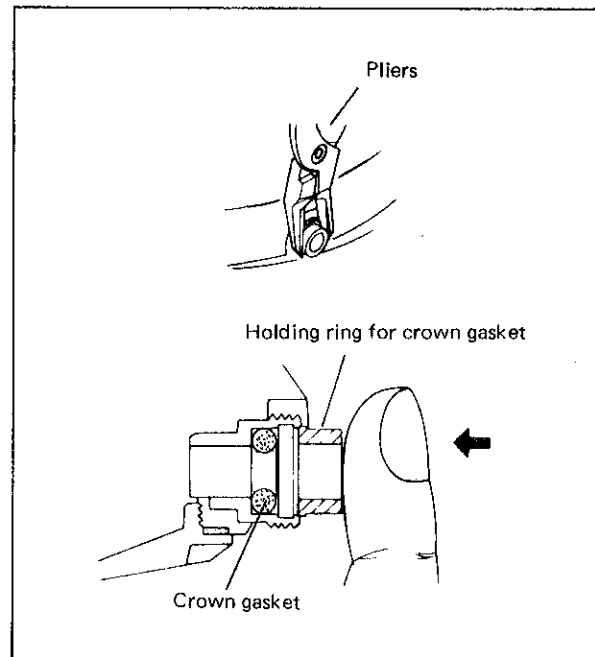

EMMYWATCH  
VINTAGE RESTORATIONS



**Replacing battery and Periodic check**



“●” mark shows that the battery should be replaced from April to June, 1994.

Each dot of the scale represents three months.

Cal. 2A22A diver's watch has information inscribed on the case back to show when the battery should be replaced. When replacing the battery, be sure to perform a periodic check in accordance with the procedures below.

**Note:**

The following measuring instruments are necessary to perform a periodic check.

1. Microscope
2. Micro Test
3. Quartz Tester
4. Water Resistance Testing Machine

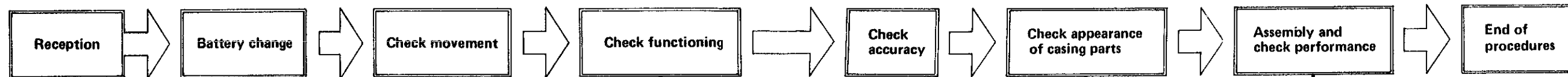

Conduct the whole checks below:

1. Check the movement for dust and lint and oil condition. (Check the movement, giving particular care to the gear train by using a microscope.)
2. Check the battery life indicator. (Check to see whether the second hand moves at 2-second intervals when the output voltage is set on 1.30V ~ 1.48V.)
3. Check the operational turn-off voltage. (Check the minimum voltage at which the watch keeps functioning correctly by using the Micro Test Standard Value 1.3V or less.)
4. Check current consumption. (Standard value 1.0μA or less)

If any defects and malfunctions are found:

- In case of 1 : Clean and lubricate every part of the movement.
- In case of 2 : Replace the circuit block with a new one.
- In case of 3, 4: Clean and lubricate the gear train, and if further malfunctions are found, replace the circuit block with a new one.

1. Check the movement of the hands.
2. Check train wheel setting condition.
3. Check date setting function.

If any malfunctions are found in the above check, check the gear train and setting mechanism to replace abnormal parts with new ones.

Check to see if the casing parts have scratches and breaks. And be sure to replace the gaskets and push pins with new ones. (Don't replace the crown gasket if no malfunction is found.)

After checking, be sure to inscribe the “●” mark on the case back showing the expected time of the next battery replacement. (Punch a mark or make a noticeable inscription.)

1. Check appearance and functions. [Check the operation of the crown and the rotating ring.]
2. Water resistance test.



[Example]

Next battery change should be performed from April to June, 1985.