



Ronda 702,703,705,708,712,713,715 Movement Parts (1)

Compiled by EmmyWatch - <https://www.emmywatch.com>

Technische Anleitung Instructions techniques No. 300.5 Technical Instructions



10 1/2'''



702



703

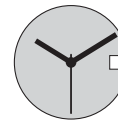

705



708



11 1/2'''



712

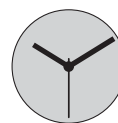

713

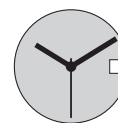

715

1. Werkdimensionen

1. Dimensions des mouvements

1. Movement dimensions

Kaliber Calibre Caliber	Ø Total	Ø Werksitz Ø Encageage Ø Case fitting	Werkhöhe Hauteur mouvement Movement height	Höhe Batterie Hauteur pile Height of battery	Höhe Stellwelle Hauteur tige Height of stem	Höhe Werkauflage Hauteur filet Movement rest
Einh./ Unité/ Unit	mm	mm	mm	mm	mm	mm
702-705	23,90	23,30	2,50	2,65	1,00	0,60
708	23,90	23,30	2,98	3,13	1,48	1,08
712-715	26,20	25,60	2,55	2,65	1,05	0,60
Stellwellengewinde/ Filetage de la tige/ Stem thread: Ø 0,90 mm				Weg/ Chemin/ Length of travel: 0,80 mm		

2. Funktionen

2. Fonctions

2. Functions

Kaliber Calibre Caliber	Stellwellenpos. Pos. de tige Stem position	Funktionen Fonctions Functions
702-703 712-713	1	Normale Position / Position normale / Running position Zeiger stellen, Sekunden-Stopp mit Unterbruch der Motorimpulse Mise à l'heure, stop-seconde avec interruption des impulsions moteur Hand setting, stop-second with interruption of motor impulses
	2	Datumkorrektur / Correction de la date / Date correction
705-708, 715	1	Normale Position / Position normale / Running position
	2	Datumkorrektur / Correction de la date / Date correction
705-708, 715	3	Zeiger stellen, Mond stellen, Sekunden-Stopp mit Unterbruch der Motorimpulse Réglage heure/phase lunaire, stop-seconde avec interruption des impulsions moteur Hand setting, moon setting, stop-second with interruption of motor impulses
		Sperrzeiten für Kalenderschnellkorrektur: 21'30 - 03'00 Uhr Restrictions: ne pas faire de correction rapide du calendrier entre 21'30 et 03'00 h Prohibition: do not use quick change date function between 21'30 and 03'00 h

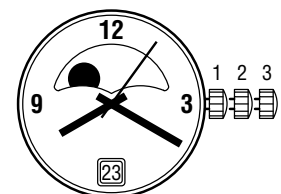

Werkaufbau

Assemblage

Assembling

10 1/2''' 702, 703, 705, 708
 11 1/2''' 712, 713, 715

10 1/2''' 702, 703
 11 1/2''' 712, 713

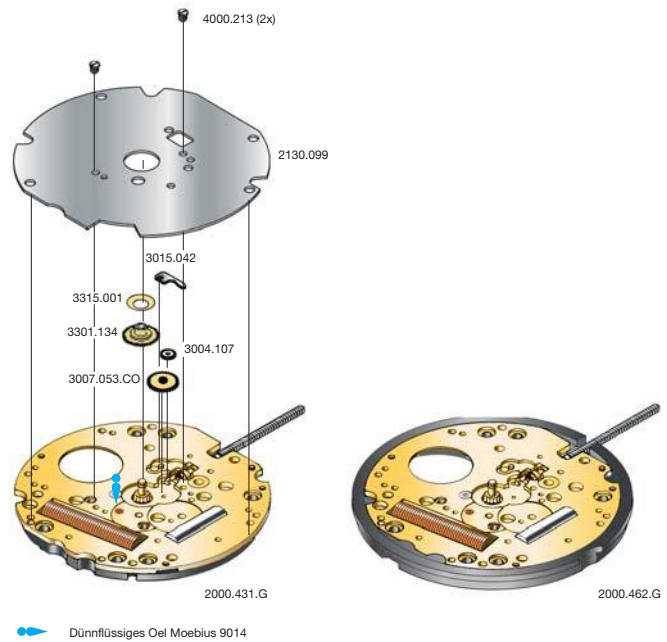
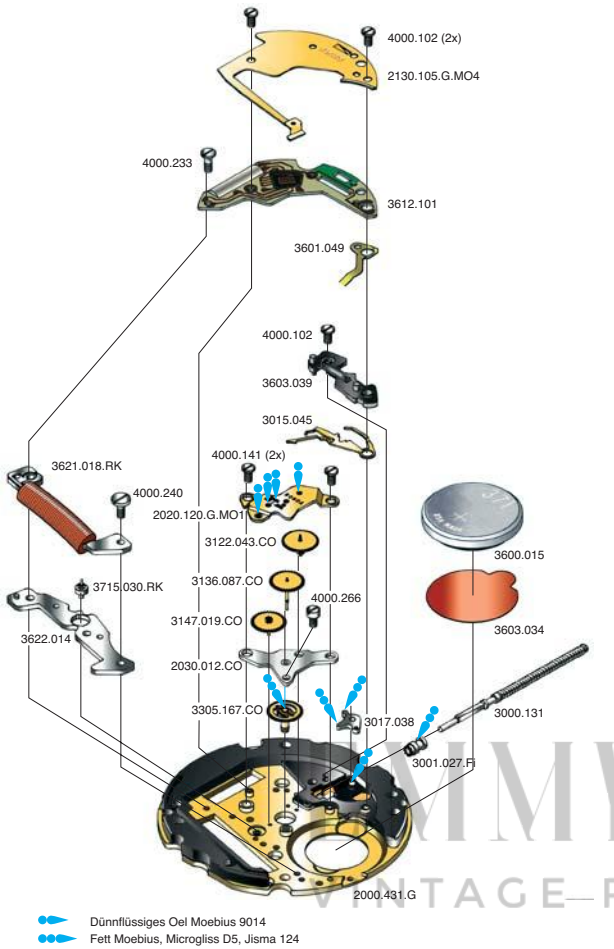

Abweichungen / Divergences / Deviations

Cal. 702	Werkseite / Côté mouvement / Movement side		
Plan No.	Bestandteile	Fournitures	Spare Parts
3136.093.CO	Sekundenrad	Roue secondes	Second wheel
3305.176.CO	Minutenrohr	Chaussée	Cannon pinion

Cal. 705	Werkseite / Côté mouvement / Movement side		
Plan No.	Bestandteile	Fournitures	Spare Parts
3015.040	Wippe	Bascule	Yoke

Cal. 708	Werkseite / Côté mouvement / Movement side		
Plan No.	Bestandteile	Fournitures	Spare Parts
2030.014.CO	Zentrumbrücke	Pont centre	Centre bridge
3015.040	Wippe	Bascule	Yoke
3136.090.CO	Sekundenrad	Roue secondes	Second wheel
3305.171.CO	Minutenrohr	Chaussée	Cannon pinion

Cal. 712	Werkseite / Côté mouvement / Movement side		
Plan No.	Bestandteile	Fournitures	Spare Parts
2000.462.G	Werkplatte	Platine	Main plate
3000.155	Stellwelle	Tige	Stem
3136.093.CO	Sekundenrad	Roue secondes	Second wheel
3305.176.CO	Minutenrohr	Chaussée	Cannon pinion

Cal. 713	Werkseite / Côté mouvement / Movement side		
Plan No.	Bestandteile	Fournitures	Spare Parts
2000.462.G	Werkplatte	Platine	Main plate
3000.155	Stellwelle	Tige	Stem

Cal. 715	Werkseite / Côté mouvement / Movement side		
Plan No.	Bestandteile	Fournitures	Spare Parts
2000.462.G	Werkplatte	Platine	Main plate
3000.155	Stellwelle	Tige	Stem
3015.040	Wippe	Bascule	Yoke

Plan No.	Bestandteile	Fournitures	Spare Parts
2000.431.G	Werkplatte	Platine	Main plate
2020.120.G.MO1	Räderwerkbrücke	Pont rouge	Train w. bridge
2030.012.CO	Zentrumbrücke	Pont centre	Centre bridge
2130.105.G.MO4	Modul-Abdeckp.	Couvre module	Module cover pl.
3000.131	Stellwelle	Tige	Stem
3001.027.FI	Kupplungstrieb	Pignon coulant	Sliding pinion
3015.045	Wippe	Bascule	Yoke
3017.038	Winkelhebel	Tirette	Setting lever
3122.043.CO	Kleinbodenrad	Roue moyenne	Third wheel
3136.087.CO	Sekundenrad	Roue secondes	Second-wheel
3147.019.CO	Zwischenrad	Roue interméd.	Intermed. wheel
3305.167.CO	Minutenrohr	Chaussée	Cannon pinion
3600.015	Batterie	Pile	Battery
3601.049	Batterie-Kontakt	Bride contact	Battery contact
3603.034	Batterie-Isolation	Isolateur pile	Battery insulation
3603.039	Deckplatte	Couvre mécan.	Setting lev. cover
3612.101	Modul	Module	Module
3621.018.RK	Spule	Bobine	Coil
3622.014	Stator	Stator	Stator
3715.030.RK	Rotor	Rotor	Rotor
4000.102	Schraube	Vis	Screw
4000.141	Schraube	Vis	Screw
4000.233	Schraube	Vis	Screw
4000.240	Schraube	Vis	Screw
4000.266	Schraube	Vis	Screw

Werkaufbau

Assemblage

Assembling

10 1/2''' 705

11 1/2''' 715

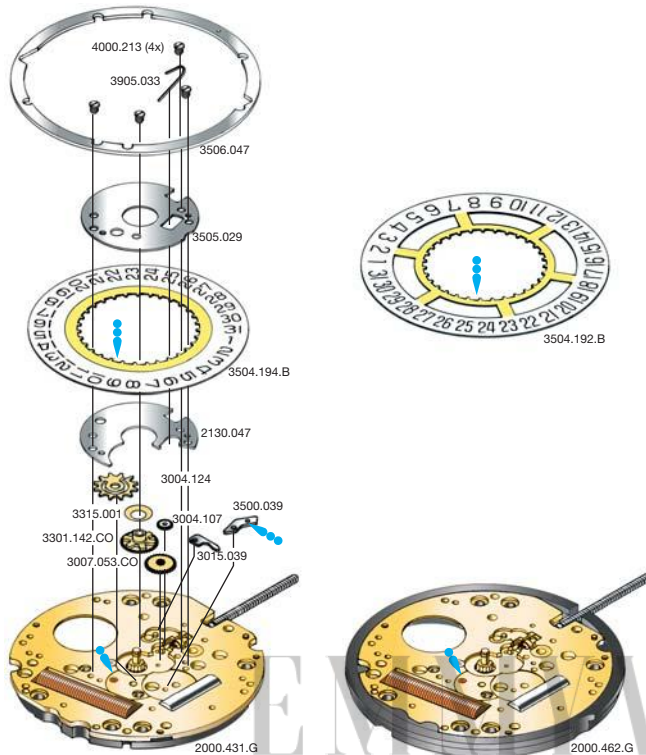

Dünnflüssiges Öl Moebius 9014
 Fett Moebius, Microgliss D5, Jisma 124

10 1/2''' 708

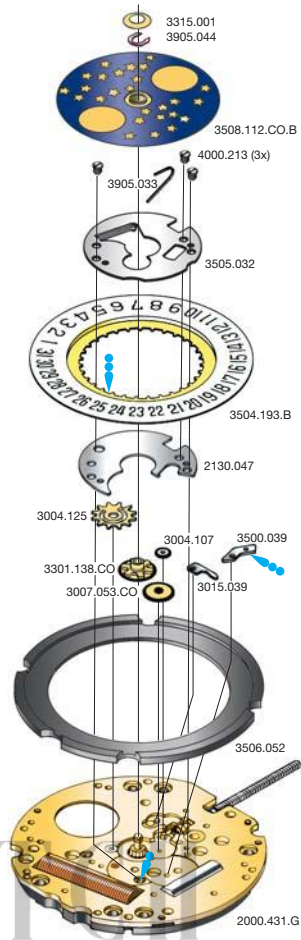

Dünnflüssiges Öl Moebius 9014
 Fett Moebius, Microgliss D5, Jisma 124

Cal. 705	Zifferblattseite / Côté cadran / Dial side		
Plan No.	Bestandteile	Fournitures	Spare Parts
2000.431.G	Werkplatte	Platine	Main plate
2130.047	Kalenderplatte	Plaque calendrier	Date ind. plate
3004.107	Zeigerstellrad	Renvoi minuterie	Setting wheel
3004.124	Datummitn.-rad	Renvoi entrain.	Ind. driving wh.
3007.053.CO	Wechselrad	Minuterie	Minute wheel
3015.039	Wippe unten	Bascule dessous	Lower sec. yoke
3301.142.CO	Stundenrad	Canon	Hour wheel
3315.001	Spreizfeder 2 1/2	Clinquant 2 1/2	Washer 2 1/2
3500.039	Datumraste	Cliquet calendrier	Date jumper
3504.194.B	Datumanzeiger	Bague	Date indicator
3505.029	Kal.-Abdeckplatte	Couvercle calend.	Date ind. guard
3506.047	Zifferbl.-Stützring	Support cadran	Dial support
3905.033	Feder Datumraste	Ressort cliquet	Date jumper spr.
4000.213	Schraube	Vis	Screw

Batterien / Piles / Batteries

702-708, 712-715	Nr. 371	SR 920 SW
	Dim.Ø x H:	9,50 x 2,06

Abweichungen / Divergences / Deviations

Cal. 702, 703 Zifferblattseite / Côté cadran / Dial side			
Plan No.	Bestandteile	Fournitures	Spare Parts
2130.099	Zeigerw.-haltepl.	Plaque maintien	Maintaining plate
3015.042	Wippe unten	Bascule dessous	Yoke sec.-yoke
3301.134	Stundenrad	Canon	Hour wheel

Cal. 708 Zifferblattseite / Côté cadran / Dial side			
Plan No.	Bestandteile	Fournitures	Spare Parts
3004.125	Datummitn.-rad	Renvoi entrain.	Ind. driv. wheel
3301.138.CO	Stundenrad	Canon	Hour wheel
3504.193.B	Datumanzeiger	Bague	Date indicator
3505.032	Kalenderdeckplatte	Couvercle calend.	Date ind. guard
3506.052	Zifferblattstützr.	Support cadran	Dial support
3508.112.CO.B	Mondscheibe	Disque lune	Moon indicator
3905.044	Klemme Monds.	Clavette disque	Moon ind. sp. clip

Cal. 712/713 Zifferblattseite / Côté cadran / Dial side			
Plan No.	Bestandteile	Fournitures	Spare Parts
2000.462.G	Werkplatte	Platine	Main plate
2130.099	Zeigerw.-haltepl.	Plaque maintien	Maintaining plate
3015.042	Wippe unten	Bascule dessous	Yoke sec.-yoke
3301.134	Stundenrad	Canon	Hour wheel

Cal. 715 Zifferblattseite / Côté cadran / Dial side			
Plan No.	Bestandteile	Fournitures	Spare Parts
2000.462.G	Werkplatte	Platine	Main plate
3405.192.B	Datumanzeiger	Bague	Date indicator

3. Leistungen

3. Performances

3. Performances

Kaliber Calibre Caliber	Bedingungen Conditions Conditions	Momentaner Gang Marche instantanée Instantaneous rate	Stromaufnahme Consommation courant Power consumption	Drehmoment Couple utile Torque	Gangreserve Autonomie Autonomy
	Einheit / Unité / Unit Typ.Wert / Valeur / value	Mi (s/month)	I (µA)	T (µNm) sec. min.	A (Monat/mois/month)
702-715	1,55 V 23°C Batt./ Pile 43,0 mAh	- 10/+ 20	0,80	8 440	74
Magnetfeldabschirmung / Résist. aux champs magn. / Resist. to magnetic fields			18,8 Oe	1500 A/M	Norm 
Betriebstemperatur / Température d'opération / Operating temperature			0-50°C		
Schockresistenz / Résistance au choc/ Shock resistance			NIHS 91-10		

Anzeige Ende der Batterielaufzeit EOL

Der Sekundenzeiger hält während 4 Sekunden an und holt dann die 4 Sprünge kurzfristig nach.

Indication de fin de vie de pile

L'aiguille de seconde s'arrête durant 4 secondes puis fait rapidement 4 pas.

Battery end-of-life indication EOL

The second hand stops for 4 seconds before executing rapidly the 4 steps.

Folgende Kaliber sind mit dem EOL-System ausgerüstet:

Les calibres suivants sont munis du système EOL:

The following calibers are equipped with EOL:

Swiss Made 703, 705, 708, 713, 715

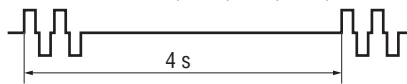

4. Elektr. Messungen

4. Contrôles électriques

4. Electrical checking

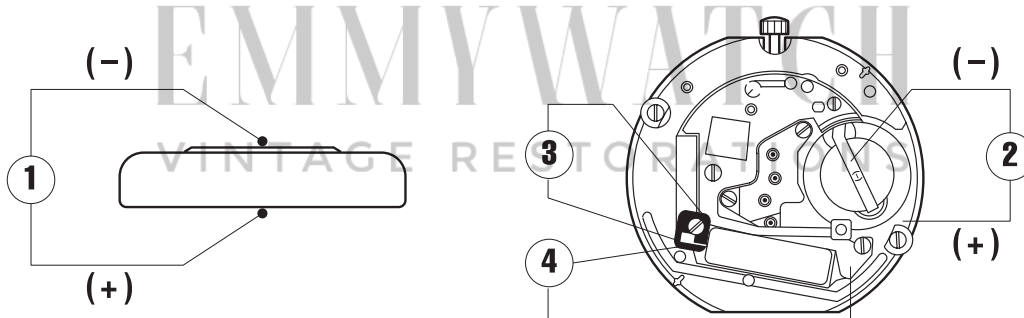

Kaliber Calibre Caliber	Pos. Pos. Pos.	Einheit Unité Unit	Messwerte Valeurs mesurées Measured values	Kontrolle Contrôle Check	Bemerkungen Remarques Remarks
702-715	1	V	1,55	Batterie-Spannung Tension de la pile Battery voltage	Batterie herausnehmen und messen Enlever et mesurer la pile Remove battery for measuring
702-715	2	µA	0,80 < 1,13	Stromaufnahme Consommation de courant Power consumption	Ohne Batterie, mit externer Speisung Sans pile, avec alimentation externe Without battery, with external power supply
702-715	2	V	< 1,35	Funktionskontrolle bei Minimalspannung Contrôle de fonctionnement à tension minimale Check with lowest possible voltage	Ohne Batterie, mit externer Speisung Sans pile, avec alimentation externe Without battery, with external power supply
702-715	3	KΩ	1,70-2,40	Spulenwiderstand Résistance de la bobine Resistance of the coil	Ohne Batterie Sans pile Without battery
702-715	4	KΩ	∞	Spulenisolation Isolation de la bobine Coil insulation	Ohne Batterie Sans pile Without battery
702-715		Sek./Monat sec./mois sec./month	- 10/+ 20	Induktivsonde 60 Sek. Senseur inductif 60 sec. Inductive sensor 60 sec.	Mit Batterie Avec pile With battery

5. Zeigerwerk

5. Aiguillage

5. Dial-train

Kaliber Calibre Caliber	Zeigerwerk Aiguillage Height of dial train	Einzelteil-Höhe mm Hauteur de la pièce ind. mm Height of individ. piece mm				Höhe ab Zifferblattaufgabe mm Dépassement platine mm Height from base mm			
		No.	A	B	C	D	E	F	G
702, 712	0		2,12	1,12	2,83	1,62	0,93	0,65	-
703, 705, 713, 715			2,09	1,12	3,67	1,62	0,90	0,65	1,20
708		-	-	-	-	-	-	-	-
702, 712	1		2,32	1,27	2,83	1,62	1,13	0,80	-
703, 705, 713, 715			2,29	1,27	3,92	1,62	1,10	0,80	1,45
708			2,77	1,75	4,44	2,09	1,10	0,80	1,45
702, 712	2		2,52	1,47	2,83	1,62	1,30	1,00	-
703, 705, 713, 715			2,49	1,47	4,12	1,62	1,30	1,00	1,65
708		-	-	-	-	-	-	-	-

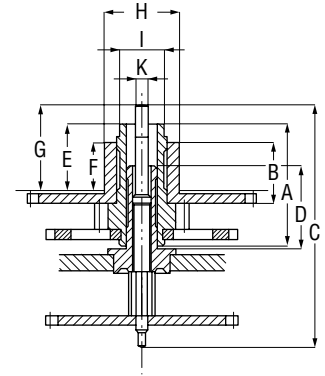

Die Zeiger dürfen nur bei zentral abgestützter Räderwerkbrücke gesetzt werden.
Der Aufpressdruck darf 25 N (2,5 kp) nicht übersteigen.

Lors de la pose des aiguilles, le pont de rouage doit être soutenu.
La force de chassage ne doit pas dépasser 25 N (2,5 kp).

Hands can only be set if train wheel bridge is supported by a movement holder.
Pressure while setting hands must not exceed 25 N (2,5 kp).

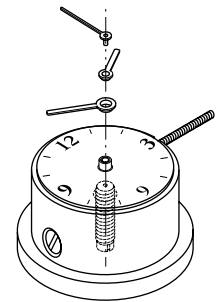

6. Einschalen

6. Emboîtement

6. Casing

Ø Zeigeranpassung mm Ø Ajustement des aiguilles mm Ø Adjustment of hands mm	H	I	K
	1,20	0,70	0,20

Zifferblattstärke mm Épaisseur du cadran mm Dial thickness mm	L
0	0,30
1 standard	0,40

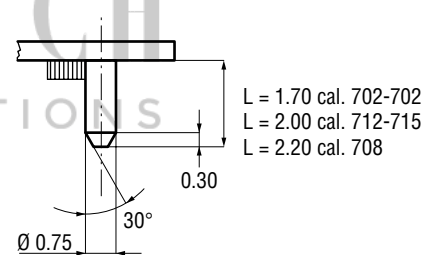

Für Einzelheiten verlangen Sie bitte die entsprechenden Zeigerwerkpläne!
Pour plus de détails demandez nos plans d'aiguillage!
For more detailed information please ask for the corresponding hand drawings!

10 1/2 "" 702, 703, 705, 708

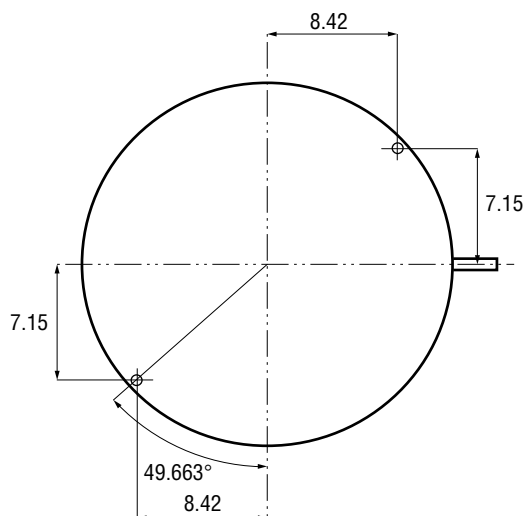

Zifferblattseite
Côté cadran
Dial side

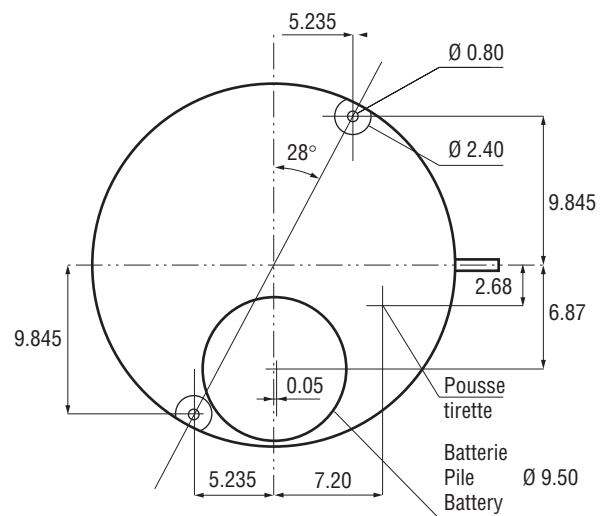

Seite gegen Gehäuseboden
Côté fond de boîte
Case back side

10 1/2 "" 702, 703, 705

Gehäuseplan
Plan de cage
Case drawing

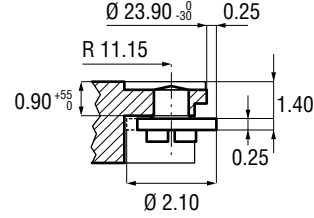
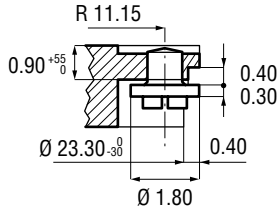
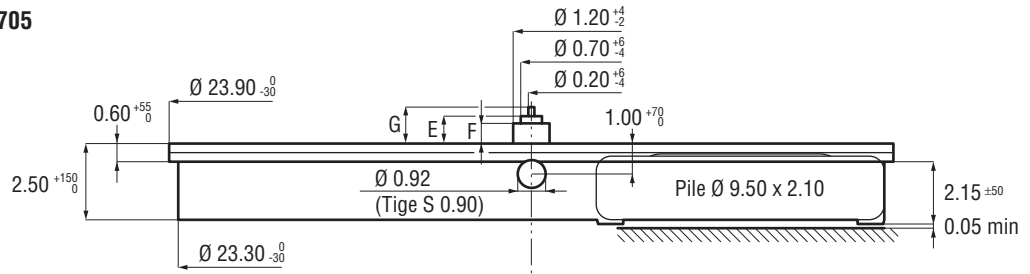

Werkbefestigungsschraube
Vis d'emboîtage
Disc screw for casing
No. 4000.236

Werkbefestigungsschraube
Vis d'emboîtage
Disc screw for casing
No. 4000.237

11 1/2 "" 712, 713, 715

Gehäuseplan
Plan de cage
Case drawing

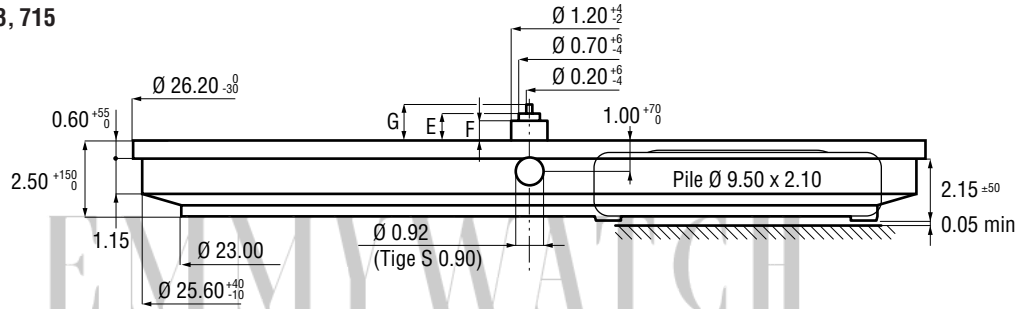

Einschalen ohne Werkbefestigungsschrauben
A emboîter sans vis d'emboîtage
Casing without disc screw

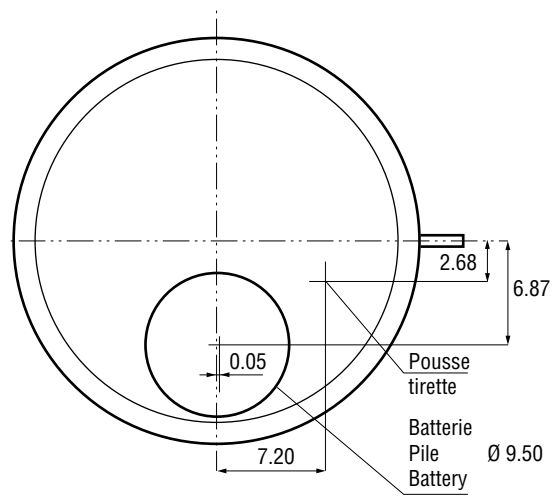
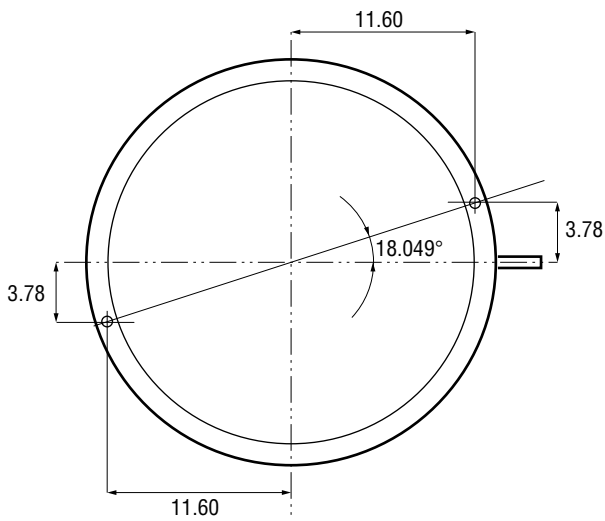

Zifferblattseite
Côté cadran
Dial side

Seite gegen Gehäuseboden
Côté fond de boîte
Case back side

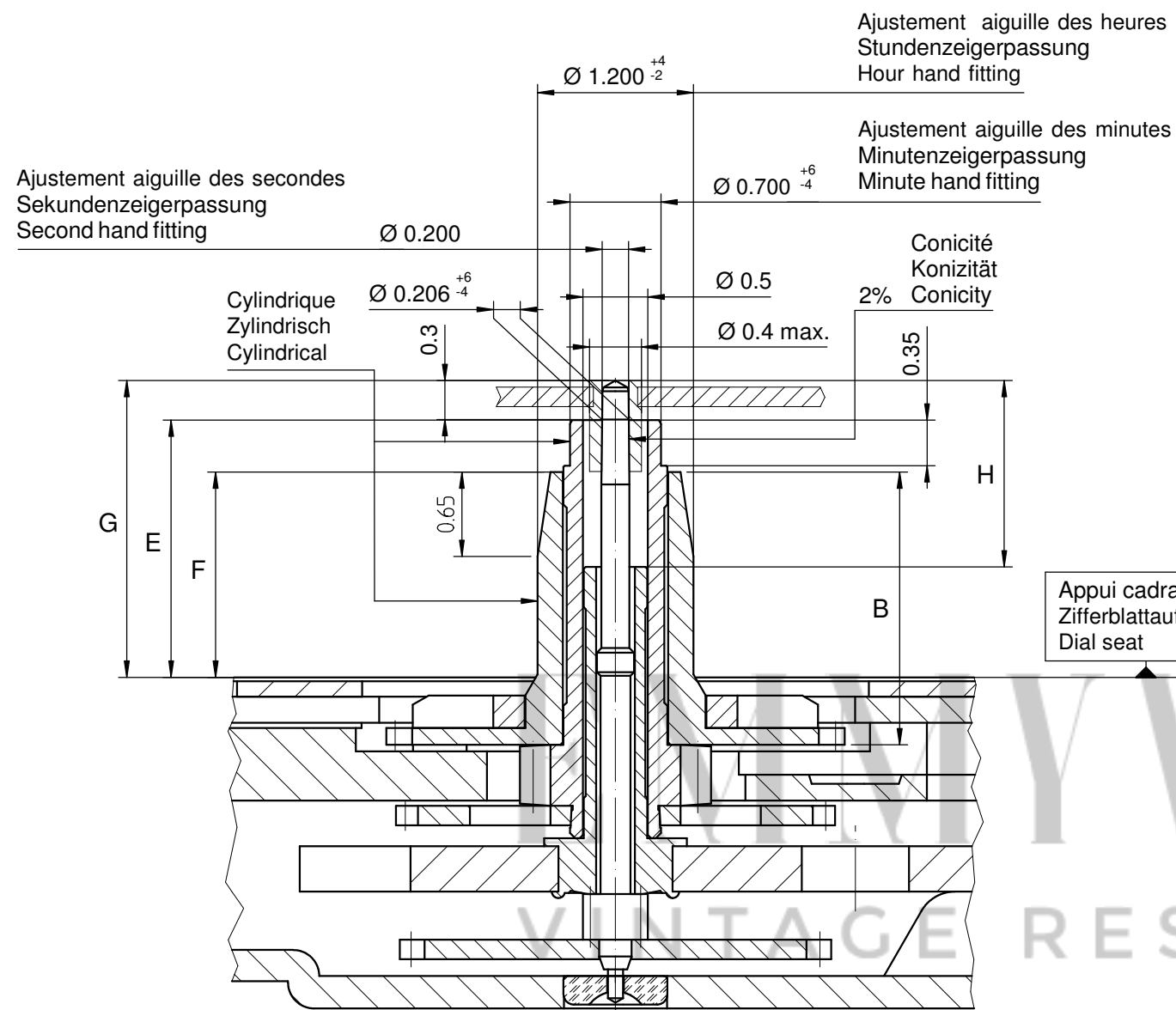

Heures / minutes / secondes
 Stunden / Minuten / Sekunden
 Hours / minutes / seconds

Aiguillage no Zeigerwerkhöhe Nr. Hand fitting height No	Dépassement Höhe über Zifferblattaufgabe Height over dial seat			Longueur Länge Length		Epaisseur max. (peinture comprise) Max. Dicke (inkl. Farbe) Max. thickness (paint included)			
	Pignon des secondes Sekundentrieb Second pinion	Chaussée Minutenrohr Cannon-pinion	Roue des heures Stundenrad Hour wheel		Roue des heures Stundenrad Hour wheel	Cadran Zifferblatt Dial			Aiguilles Zeiger Hands
	G	E	F	H	B	Sous l'aiguille des secondes Unter Sekundenzeiger Under second hand	Sous l'aiguille des minutes Unter Minutenzeiger Under minute hand	Sous l'aiguille des heures Unter Stundenzeiger Under hour hand	
6	2.29	1.98	1.58	1.44	2.10	1.75	1.55	0.40	0.15
-									

YWATCH
 VINTAGE RESTORATIONS

		Aig. des secondes Sekundenzeiger Second hand	Aig. des minutes Minutenzeiger Minute hand	Aig. des heures Stundenzeiger Hour hand	Lors de la pose d'aiguilles, le mouvement doit être soutenu. Beim Zeigersetzen muss das Werk abgestützt werden. The movement needs to be supported for hand setting.
		775, 785	705, 715, 715Li	Alle/Tous/All	Kaliber/Calibre/Caliber
mg	max.	10	10	30	Masse / Masse / Weight *
µNm	max.	0.05	0.05	0.70	Balourd / Unwucht / Unbalance *
gmm ²	max.	0.2	0.4	-	Inertie / Massenträgheit / Inertia *
N	max.	30	30	40	Force de chassage / Aufpresskraft / Force

Sous réserve de toutes modifications

Aenderungen vorbehalten

All modifications reserved

Aiguillages Zeigerwerkhöhen Hand fitting heights	7 ³ / ₄ " , 8 ³ / ₄ "	Issued	14 Okt 2002	cw
	10 ¹ / ₂ " , 11 ¹ / ₂ "	Modified	03 Feb 2012 ÄA 12073	ds
		Released	Yes	
		Tolerance	µm	
		Scale	20 : 1 (A3H)	
RONDA	775, 785, 705, 715, 715Li	Sous réserve de modifications Aenderungen vorbehalten Modifications reserved		
		No.	3316.077	08

* En cas de données différentes, veuillez contacter le service après-vente

* Bei abweichenden Werten, bitte technischen Kundendienst anfragen

* In case of different values, please contact the customer service

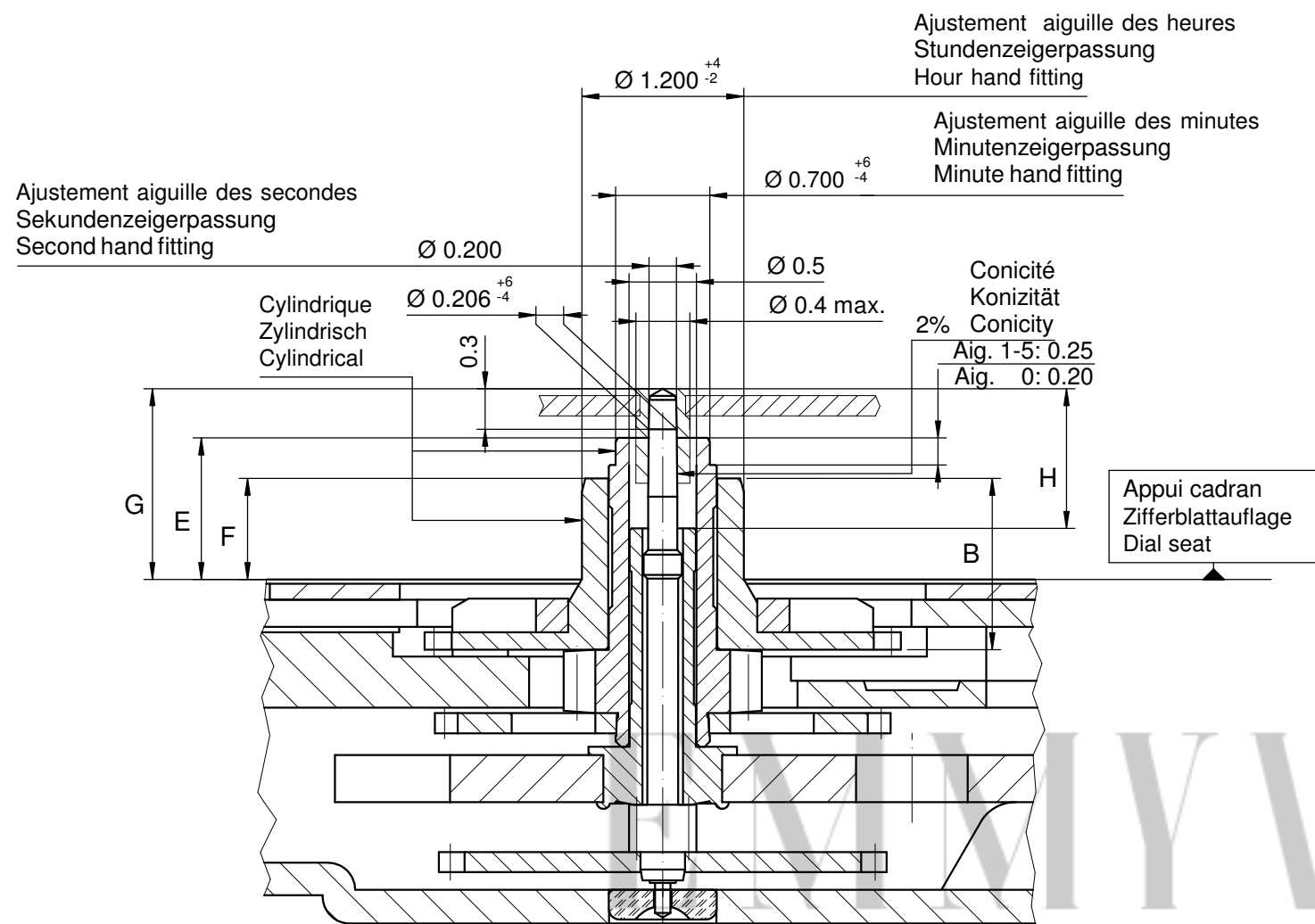

Heures / minutes / secondes
Stunden / Minuten / Sekunden
Hours / minutes / seconds

Aiguillage no Zeigerwerkhöhe Nr. Hand fitting height No	Dépassement Höhe über Zifferblattauflage Height over dial seat			Longueur Länge Length		Epaisseur max. (peinture comprise) Max. Dicke (inkl. Farbe) Max. thickness (paint included)			
	Pignon des secondes Sekundentrieb Second pinion	Chaussée Minutenrohr Cannon-pinion	Roue des heures Stundenrad Hour wheel			Cadran Zifferblatt Dial			Aiguilles Zeiger Hands
	G	E	F	H	B	Sous l'aiguille des secondes Unter Sekundenzeiger Under second hand	Sous l'aiguille des minutes Unter Minutenzeiger Under minute hand	Sous l'aiguille des heures Unter Stundenzeiger Under hour hand	
0	1.17	0.85	0.60	0.79	1.12	0.65	0.45	0.30	0.15
1	1.42	1.05	0.75	1.04	1.27	0.90	0.65	0.40	0.15
2	1.62	1.25	0.95	1.24	1.47	1.10	0.85	0.60	0.15
3	1.94	1.53	1.23	1.09	1.75	1.40	1.10	0.90	0.15
4	2.29	1.88	1.58	1.44	2.10	1.75	1.45	1.25	0.15
5	3.95	3.55	3.24	1.59	3.76	3.45	3.15	2.90	0.15

		Aig. des secondes Sekundenzeiger Second hand	Aig. des minutes Minutenzeiger Minute hand	Aig. des heures Stundenzeiger Hour hand	Lors de la pose d'aiguilles, le mouvement doit être soutenu. Beim Zeigersetzen muss das Werk abgestützt werden. The movement needs to be supported for hand setting.
		775, 785	705, 715, 715Li	Alle/Tous/All	Kaliber/Calibre/Caliber
mg	max.	10	10	30	30
μNm	max.	0.05	0.05	0.70	0.70
gmm ²	max.	0.2	0.4	-	-
N	max.	30	30	40	40
					Masse / Masse / Weight *
					Balourd / Unwucht / Unbalance *
					Inertie / Massenträgheit / Inertia *
					Force de chassage / Aufpresskraft / Force

Sous réserve de toutes modifications

Aenderungen vorbehalten

All modifications reserved

Aiguillages
Zeigerwerkhöhen
Hand fitting heights

7³/₄" , 8³/₄"
10¹/₂" , 11¹/₂"

Issued	09 Aug 1990	rh
Modified	07 Feb 2012 ÄA 12073	ds
Released	Yes	
Tolerance	μm	
Scale	20 : 1 (A3H)	

RONDA

775, 785, 705, 715,
715Li

Sous réserve de modifications
Aenderungen vorbehalten
Modifications reserved

No.	3316.030	14
-----	----------	----