



EMMYWATCH
VINTAGE RESTORATIONS

Ronda 582,583,585 Movement Parts (1)

Compiled by EmmyWatch - <https://www.emmywatch.com>



8 ³/₄'''



582

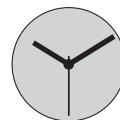

583

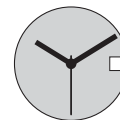

585

1. Werkdimensionen

1. Dimensions des mouvements

1. Movement dimensions

Kaliber	Ø Total	Ø Werksitz	Werkhöhe	Höhe Batterie	Höhe Stellwelle	Höhe Werkauflage
Calibre	Ø Total	Ø Encageage	Hauteur mouvement	Hauteur pile	Hauteur tige	Hauteur filet
Caliber	Ø Total	Ø Case fitting	Movement height	Height of battery	Height of stem	Movement rest
Einh./ Unité/ Unit	mm	mm	mm	mm	mm	mm
582-585	20,00	19,40	3,00	3,15	1,50	0,60
Stellwellengewinde/ Filetage de la tige/ Stem thread: Ø 0,90 mm				Weg/ Chemin/ Length of travel: 0,80 mm		

2. Funktionen

2. Fonctions

2. Functions

Kaliber	Stellwellenpos.	Funktionen
Calibre	Pos. de tige	Fonctions
Caliber	Stem position	Functions
582-583	1	Normale Position / Position normale / Running position Zeiger stellen, Sekunden-Stopp mit Unterbruch der Motorimpulse
	2	Mise à l'heure, stop-seconde avec interruption des impulsions moteur Hand setting, stop-second with interruption of the motor pulses
585	1	Normale Position / Position normale / Running position
	2	Datumkorrektur/ Correction de la date / Date correction
	3	Zeiger stellen, Sekunden-Stopp mit Unterbruch der Motorimpulse Mise à l'heure, stop-seconde avec interruption des impulsions moteur Hand setting, stop-second with interruption of the motor pulses
585		Sperrzeiten für Kalenderschnellkorrektur: 21'30 - 03'00 Uhr Restrictions: ne pas faire de correction rapide du calendrier entre 21'30 et 03'00 h Prohibition: do not use quick change date function between 21'30 and 03'00 h

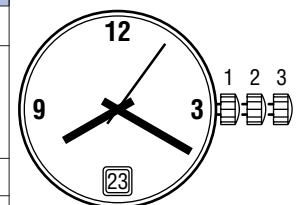

8 3/4''' 582, 583, 585

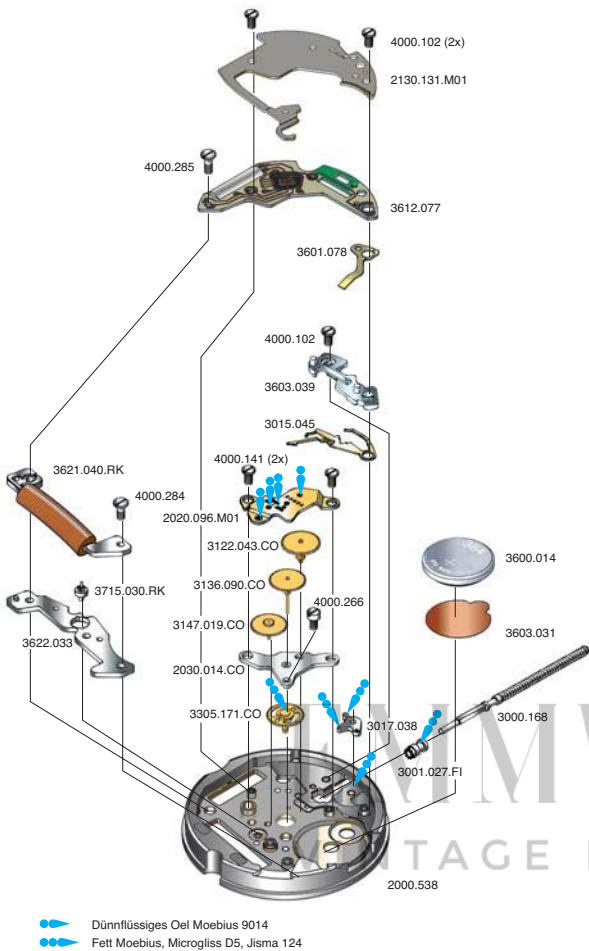

Plan No.	Bestandteile	Fournitures	Spare Parts
2000.538	Werkplatte	Platine	Main Plate
2020.096.MO1	Räderwerkbrücke	Pont rouge	Train w. bridge
2030.014.CO	Zentrumbrücke	Pont centre	Centre bridge
2130.131.MO1	Modul-Abdeckp.	Couvre module	Module cover pl.
3000.168	Stellwelle	Tige	Stem
3001.027.FI	Kupplungstrieb	Pignon coulant	Sliding pinion
3015.045	Kuppl.-triebhebel	Bascule	Yoke
3017.038	Winkelhebel	Tirette	Setting lever
3122.043.CO	Kleinbodenrad	Roue moyenne	Third wheel
3136.090.CO	Sekundenrad	Roue secondes	Second-wheel
3147.019.CO	Zwischenrad	Roue interméd.	Intermed. wheel
3305.171.CO	Minutenrohr	Chaussée	Cannon pinion
3600.014	Batterie	Pile	Battery
3601.078	Batterie-Kontakt	Bride contact	Battery contact
3603.039	Deckplatte/ Ste.	Couvre mécan.	Setting lev. cover
3603.031	Batterie-Isolation	Isolateur pile	Battery insulation
3612.077	Modul	Module	Module
3621.040.RK	Spule	Bobine	Coil
3622.033	Stator	Stator	Stator
3715.030.RK	Rotor	Rotor	Rotor
4000.102	Schraube	Vis	Screw
4000.141	Schraube	Vis	Screw
4000.266	Schraube	Vis	Screw
4000.284	Schraube	Vis	Screw
4000.285	Schraube	Vis	Screw

Abweichungen / Divergences / Deviations

Cal. 582	Werkseite / Côté mouvement / Movement side		
Plan No.	Bestandteile	Fournitures	Spare Parts
2030.012.CO	Zentrumbrücke	Ponte centre	Centre bridge
3136.093.CO	Sekundenrad	Roue secondes	Second-wheel
3305.210.CO	Minutenrohr	Chaussée	Cannon pinion

Cal.585	Werkseite / Côté mouvement / Movement side		
Plan No.	Bestandteile	Fournitures	Spare Parts
3015.040	Kuppl.triebhebel	Bascule	Yoke

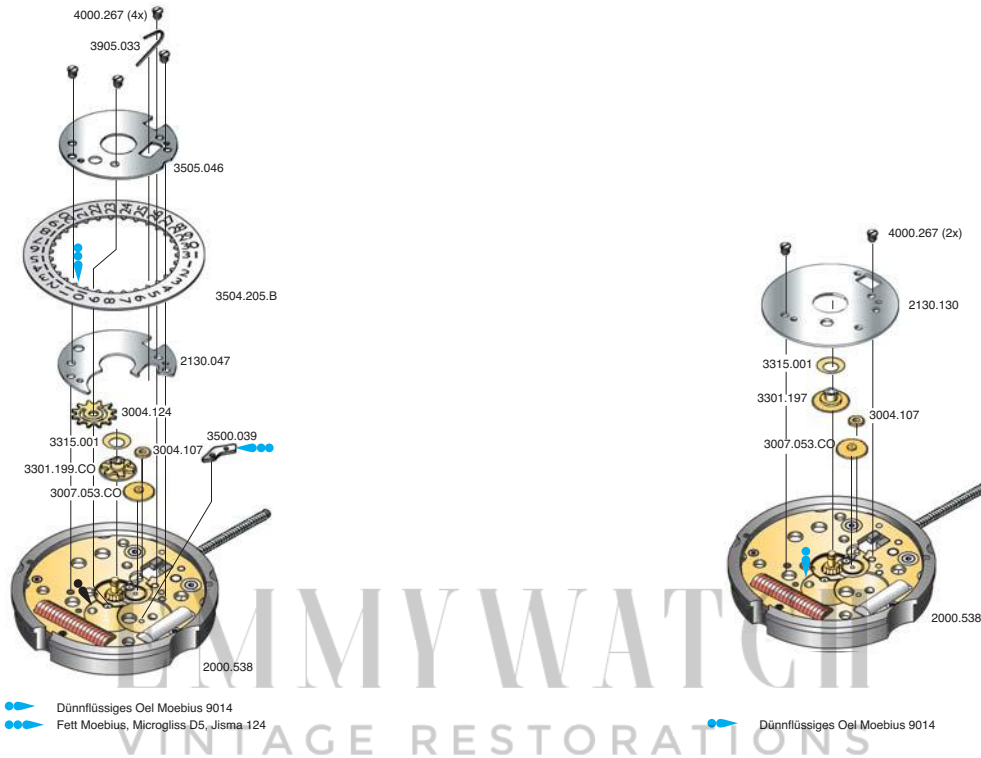

Plan No.	Bestandteile	Fournitures	Spare Parts
2130.047	Kalenderplatte	Plaque calend.	Date ind. plate
3004.107	Zeigerstellrad	Renvoi minuterie	Setting wheel
3004.124	Datummitn.-Rad	Renvoi entrain.	Ind. driving wheel
3007.053.CO	Wechselrad	Minuterie	Minute wheel
3301.199.CO	Stundenrad	Canon	Hour wheel
3315.001	Spreizfeder	Clinquant 2 1/2	Washer 2 1/2
3500.039	Datumraste	Cliquet calend.	Date jumper
3504.205.B	Datumanzeiger	Bague	Date indicator
3505.046	Kal.-Abdeckplatte	Couvercle calend.	Date ind. guard
3905.033	Feder Datumraste	Ressort calend.	Date jumper spr.
4000.267	Schraube	Vis	Screw

Batterien / Piles / Batteries

582-585	Nr. 362 Dim.Ø x H:	SR 721 SW 7,90 x 2,10
---------	-----------------------	--------------------------

Abweichungen / Divergences / Deviations

Cal. 582/583 Zifferblattseite / Côté cadran / Dial side			
Plan No.	Bestandteile	Fournitures	Spare Parts
2130.130	Zeigerwerkhaltep.	Plaque maintien	Maintaining plate
3301.197	Stundenrad	Canon	Hour wheel

3. Leistungen

3. Performances

3. Performances

Kaliber Calibre Caliber	Bedingungen Conditions Conditions	Momentaner Gang Marche instantanée Instantaneous rate	Stromaufnahme Consommation courant Power consumption	Drehmoment Couple utile Torque	Gangreserve Autonomie Autonomy
	Einheit / Unité / Unit Typ.Wert / Valeur / value	Mi (s/month)	I (µA)	T (µNm) sec. min.	A (Monat/mois/month)
582-585	1,55 V 23°C Batt./ Pile 25,0 mAh	- 10/+ 20	0,93 < 1,25	7,0 310	36
Magnetfeldabschirmung / Résist. aux champs magn. / Resist. to magnetic fields			18,8 Oe	1500 A/M	Norm CE
Betriebstemperatur / Température d'opération / Operating temperature			0-50°C		
Schockresistenz / Résistance au choc/ Shock resistance			NIHS 91-10		

4. Elektr. Messungen

4. Contrôles électriques

4. Electrical checking

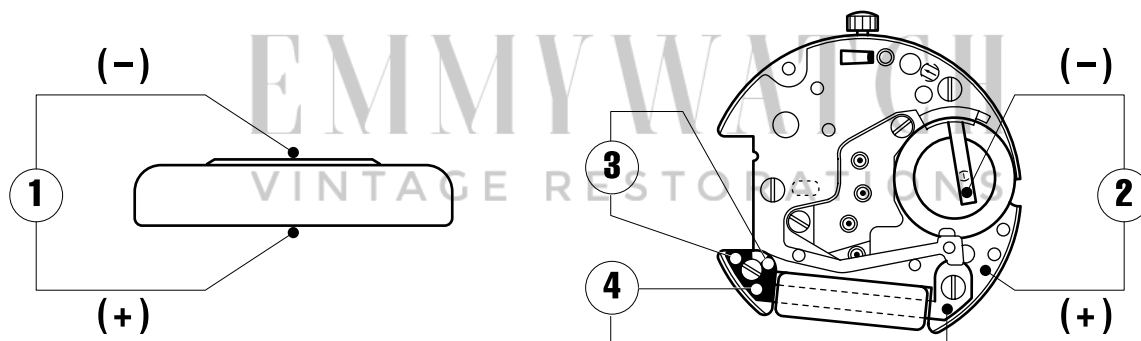

Kaliber Calibre Caliber	Pos. Pos. Pos.	Einheit Unité Unit	Messwerte Valeurs mesurées Measured values	Kontrolle Contrôle Check	Bemerkungen Remarques Remarks
582-585	1	V	1,55	Batterie-Spannung Tension de la pile Battery voltage	Batterie herausnehmen und messen Enlever et mesurer la pile Remove battery for measuring
582-585	2	µA	0,93 < 1,25	Stromaufnahme Consommation de courant Power consumption	Ohne Batterie, mit externer Speisung Sans pile, avec alimentation externe Without battery, with external power supply
582-585	2	V	≤ 1,30	Funktionskontrolle bei Minimalspannung Contrôle de fonctionnement à tension minimale Check with lowest possible voltage	Ohne Batterie, mit externer Speisung Sans pile, avec alimentation externe Without battery, with external power supply
582-585	3	KΩ	1,80-2,00	Spulenwiderstand Résistance de la bobine Resistance of the coil	Ohne Batterie Sans pile Without battery
582-585	4	KΩ	∞	Spulenisolation Isolation de la bobine Coil insulation	Ohne Batterie Sans pile Without battery
582-585		Sek./Monat sec./mois sec./month	- 10/+ 20	Induktivsonde 60 Sek. Senseur inductif 60 sec. Inductive sensor 60 sec.	Mit Batterie Avec pile With battery

5. Zeigerwerk

5. Aiguillage

5. Dial-train

Kaliber Calibre Caliber	Zeigerwerk Aiguillage Height of dial train	Einzelteil-Höhe mm				Höhe ab Zifferblattauflage mm		
		A	B	C	D	E	F	G
582	No.							
	1	2,80	1,75	2,83	1,62	1,13	0,80	-
	2	3,12	2,10	2,83	1,62	1,45	1,15	-
583-585	3	3,37	2,32	2,83	1,62	1,70	1,37	-
	1	2,77	1,75	4,44	2,09	1,10	0,80	1,50
	2	3,12	2,10	4,79	2,09	1,45	1,15	1,85

8 ³/₄''' 582, 583, 585

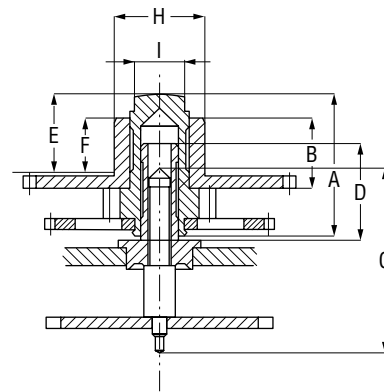
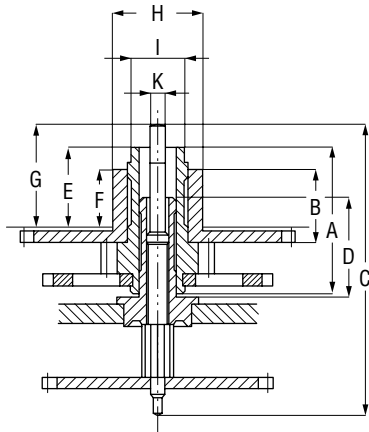

EMMYWATCH
VINTAGE RESTORATIONS

6. Einschalen

6. Emboîtage

6. Casing

Ø Zeigeranpassung	mm	
Ø Ajustement des aiguilles	mm	
Ø Adjustment of hands	mm	
H	I	K
1,20	0,70	0,20

Zifferblattdicke	mm
Epaisseur du cadran	mm
Dial thickness	mm
0	0,30
1 standard	0,40

Für Einzelheiten verlangen Sie bitte die entsprechenden Zeigerwerkpläne!
Pour plus de détails demandez nos plans d'aiguillage!
For more detailed information please ask for the corresponding hand drawings!

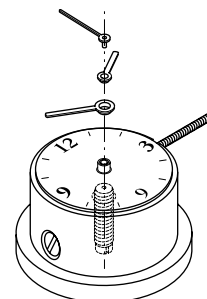
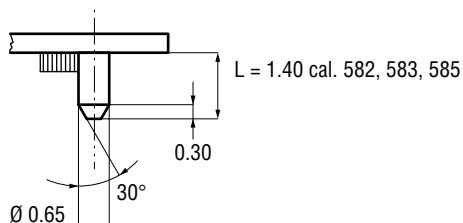

Die Zeiger dürfen nur bei zentral abgestützter Räderwerkbrücke gesetzt werden.
Der Aufpressdruck darf 30 N (3,0 kp) nicht übersteigen.

Lors de la pose des aiguilles, le pont de rouage doit être soutenu.
La force de chassage ne doit pas dépasser 30 N (3,0 kp).

Hands can only be set if train wheel bridge is supported by a movement holder.
Pressure while setting hands must not exceed 30 N (3,0 kp).

Gehäuseplan
Plan de cage
Case drawing

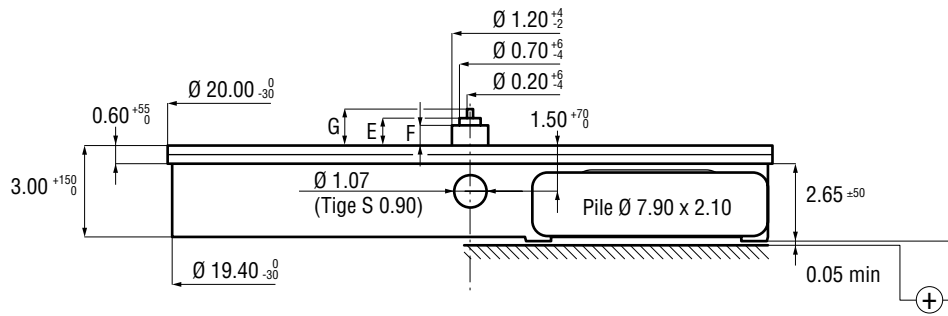

Sicherheit zwischen Werk und Boden: min. 0.15
Sécurité entre mouvement et fond de boîte: min. 0.15
Security between movement and back: min. 0.15

Sicherheit zwischen Sekundenzeiger und Glas: 0.30
Sécurité entre aiguille seconde et verre: 0.30
Security between second hand and glass: 0.30

Sicherheit zwischen Batteriefansch und Boden: min. 0.05
Sécurité entre bride de pile et fond de boîte: min. 0.05
Security between battery-clamp and back: min. 0.05

Das Zifferblatt muss in der Höhe vom Gehäuse festgehalten werden.
La cadran doit être maintenu en hauteur par la boîte.
The dial must be held in the height by the case.

Einschalen ohne Werkbefestigungsschrauben.
A emboîter sans vis d'emboîtement.
Casing without dog-screws.

EMMY WATCH
VINTAGE RESTORATIONS

Seite gegen Gehäuseboden
Côté fond de boîte
Case back side

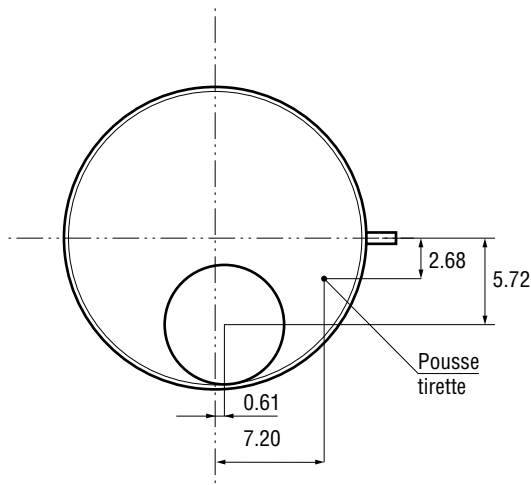

Zifferblattseite
Côté cadran
Dial side

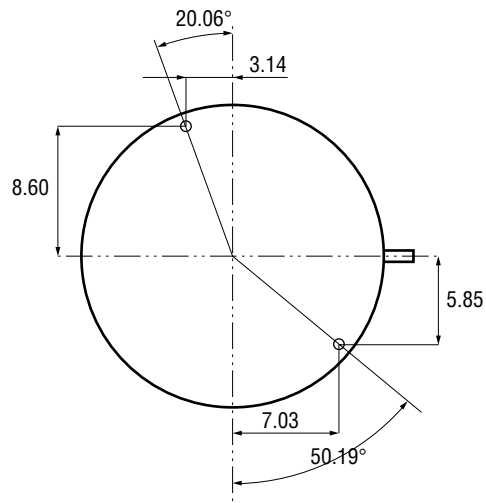

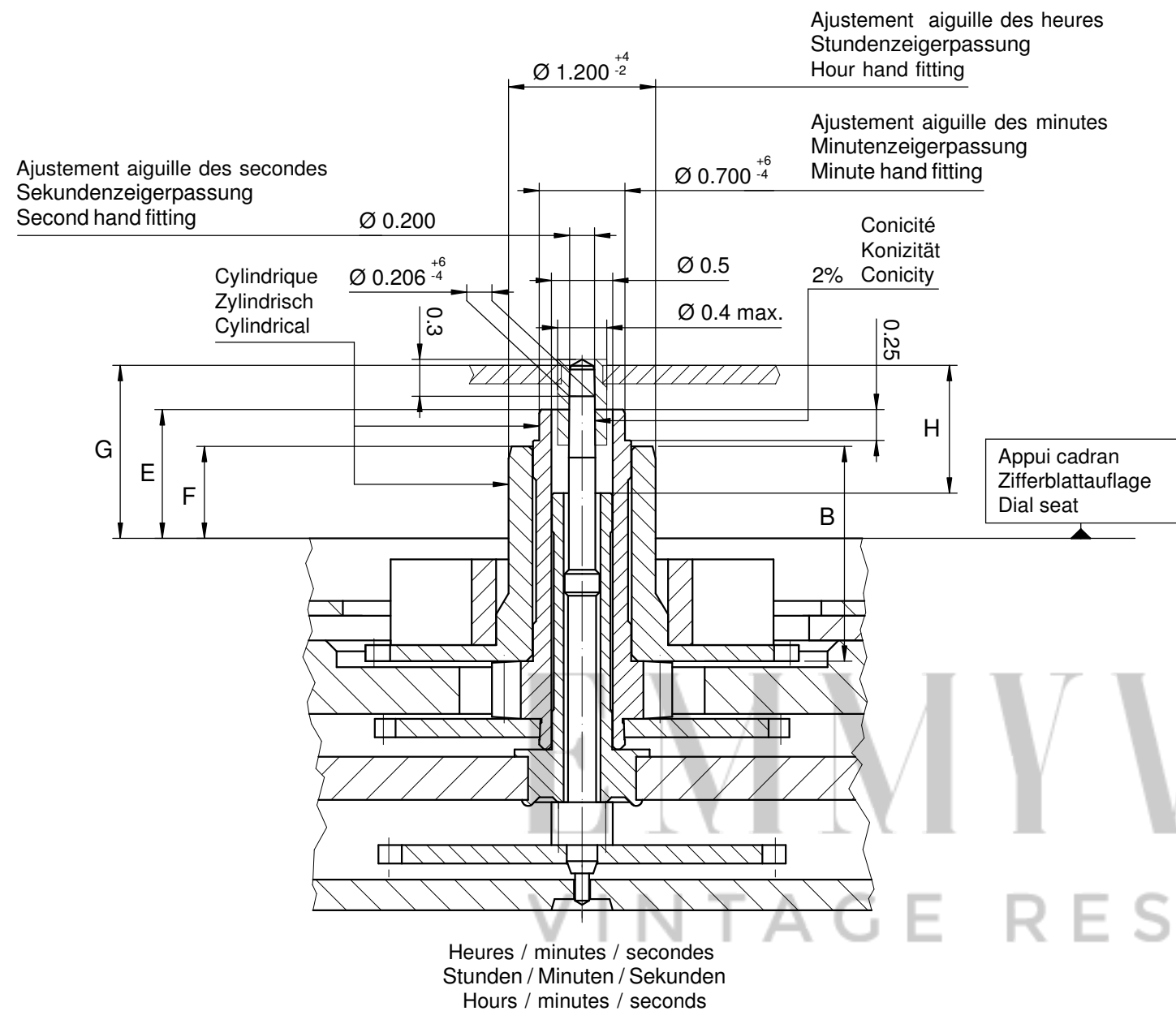

Aiguillage no Zeigerwerkhöhe Nr. Hand fitting height No	Dépassement Höhe über Zifferblattaufgabe Height over dial seat			Longueur Länge Length		Epaisseur max. (peinture comprise) Max. Dicke (inkl. Farbe) Max. thickness (paint included)			
	Pignon des secondes Sekundentrieb Second pinion	Chaussée Minutenrohr Cannon-pinion	Roue des heures Stundenrad Hour wheel	Roue des heures Stundenrad Hour wheel	Cadran Zifferblatt Dial			Aiguilles Zeiger Hands	
					Sous l'aiguille des secondes Unter Sekundenzeiger Under second hand	Sous l'aiguille des minutes Unter Minutenzeiger Under minute hand	Sous l'aiguille des heures Unter Stundenzeiger Under hour hand		
G	E	F	H	B					
1	1.45	1.05	0.75	1.09	1.75	0.95	0.65	0.40	0.15
2	1.80	1.40	1.10	1.44	2.10	1.30	1.00	0.75	0.15
5	3.45	3.05	2.76	1.59	3.76	2.95	2.65	2.40	0.15

	Aig. des secondes Sekundenzeiger Second hand	Aig. des minutes Minutenzeiger Minute hand	Aig. des heures Stundenzeiger Hour hand	Lors de la pose d'aiguilles, le mouvement doit être soutenu. Beim Zeigersetzen muss das Werk abgestützt werden. The movement needs to be supported for hand setting.
mg max.	10	30	30	Masse / Masse / Weight *
µNm max.	0.05	0.70	0.70	Balourd / Unwucht / Unbalance *
gmm ² max.	0.2	-	-	Inertie / Massenträgheit / Inertia *
N max.	30	40	40	Force de chassage / Aufpresskraft / Force

Sous réserve de toutes modifications

Aenderungen vorbehalten

All modifications reserved

Aiguillages
Zeigerwerkhöhen
Hand fitting heights

8³/₄"

RONDA

585

Issued	24 Feb 2000	ck
Modified	27 Okt 2011 ÄA 11646	dh
Released	Yes	
Tolerance	µm	
Scale	20 : 1 (A3H)	
Sous réserve de modifications Aenderungen vorbehalten Modifications reserved		
No.	3316.066	08

* En cas de données différentes, veuillez contacter le service après-vente

* Bei abweichenden Werten, bitte technischen Kundendienst anfragen

* In case of different values, please contact the customer service