



Omega 1010,1011,1012,1020,1021,1022 Movement Parts (1)

Compiled by EmmyWatch - <https://www.emmywatch.com>

CALIBERS

1010-1011-1012-1020-1021-1022

- 1010 27.90 T1 RA SC PC CAL CORR 17 p.
- 1011 27.90 T1 RA SC PC CAL CORR STS BULL. 23 p.
- 1012 27.90 T1 RA SC PC CAL CORR STS 23 p.
- 1020 27.90 T1 RA SC PC CALD CORR CORJ STS 17 p.
- 1021 27.90 T1 RA SC PC CALD CORR CORJ STS BULL 23 p.
- 1022 27.90 T1 RA SC PC CALD CORR CORJ STS 23 p.

<p>∅ 27.90 mm</p>	
<p>Frequency</p>	<p>28'800 A/h</p>



casing diameter:	27,90 mm	angle of lift of balance:	52°
height 1010 - 1011 - 1012:	4,25 mm	running time:	48 h mini
height 1020 - 1021 - 1022:	4,80 mm	thread diameter of winding stem:	0,90 mm
frequency:	28 800 A/h		

Calibers 1010 to 1022 have been developed on mathematical bases. Indeed, a method of calculation has been perfected in our laboratories whereby maximum data is obtained with regard to the chief features of the various movement parts. Thus, having the most information possible, the constructor is able to carry out his research under better-controlled conditions than previously. Trial series have confirmed the advantages of this method for, with the said caliber, we are securing timekeeping results which have as yet never been achieved by movements of the same category.

Moreover, let us mention that, if this new caliber presents obvious similarities to caliber 1000, it has nevertheless been entirely reconceived and can in no way be compared with it.

Op. No.	Order of assembling operations	Part No.	Fixing device	Lubrication point	code	Remarks
---------	--------------------------------	----------	---------------	-------------------	------	---------

1.0. WHEEL TRAIN

1.1.	center second pinion	7217				
1.2.	friction spring for center second pinion	1255	1 screw 3442	funct.	1.00	
1.3.	fourth wheel	1243				
1.4.	third wheel	1240				
1.5.	center wheel	1216				
1.6.	escape wheel	1305				
1.7.	stop lever	1123				under wheel tr. bridge 1003
1.8.	wheel train bridge	1003	2 screws 2584			

2.0. MOTOR

2.1.	barrel with arbor	1200		pivots	1.00	see 2.1.0.
2.2.	wig-wag pinion	1151				see 2.2.0.
2.3.	wig-wag pinion spring	1153	1 screw 2050			recess tangent to barrel in upper side plate
2.4.	barrel bridge	1001	2 screws 2584			
2.5.	setting wheel ring for crown wheel	1156				
2.6.	setting wheel for crown	1151	1 screw 2485	pivot	2.00	
2.7.	crown wheel	1101	1 screw 2485	pivot	2.00	fit beforehand on crown wh. core 1102
2.8.	click spring	1105				
2.9.	click	1104				
2.10.	ratchet wheel	1100	1 screw 2557			

3.0. WINDING MECHANISM

3.1.	winding pinion	1108			1.00	
3.2.	clutch wheel	1107			1.00	
3.3.	winding stem	1106			1.00	
3.4.	setting lever	1109		funct.	1.00	
3.5.	yoke	1111		pivot+funct.	1.00	
3.6.	date corrector yoke	1568		star+funct.	1.00	different for cal. 1010 and 1020
3.7.	yoke spring	1112		funct.	1.00	

Op. No.	Order of assembling operations	Part No.	Fixing device	Lubrication point	code	Remarks
---------	--------------------------------	----------	---------------	-------------------	------	---------

3.8.	yoke spr. for date corr.	1576		funct.	1.00	
3.9.	setting lever spring	1110	1 screw 2585	funct.	1.00	
3.10.	pressure spring for setting lever	1132	2 screws 2585	funct.	1.00	

4.0. ESCAPEMENT

4.1.	pallet fork	1316				
4.2.	pallet cock	1005	2 screws 2441			

5.0. OILING

5.1.	center wheel			lower	1.00	
5.2.	third wheel			lower	1.00	
5.3.	fourth wheel			lower	1.00	
5.4.	escape wheel			lower	1.00	
5.5.	center wheel			upper	1.00	
5.6.	third wheel			upper	1.00	
5.7.	fourth wheel			upper	1.00	
5.8.	escape wheel			upper	1.00	
5.9.	pallet fork			pallets	2.00	
5.10.	incabloc			lower	1.02	

6.0. ADJUSTMENT

6.1.	fitting of regulator assembly					see 6.1.0.
6.2.	oil incabloc			upper	1.02	
6.3.	fit stud to balance-cock					
6.4.	fit balance cock on plate					
6.5.	hairspring setting					

7.0. WHEEL TRAIN AND TIME DISPLAY MECHANISM

see 7.0.0.

8.0. AUTOMATIC UNIT

see 8.0.0.

2.1.0. Barrel

The spring in neotal is self-lubricated.

Oil (1.00) the bearings of the arbor (drum and cover pivots).

2.2.0. Wig-wag pinion (1151)

This pinion, located on the barrel bridge (1001), can move about in the oblong hole which serves to guide it. It is fixed by means of a screw (2558) and a lock-nut in the shape of a core (1157). The spring of the wig-wag pinion (1153), screwed on the plate (1000), acts on the pivot of the screw (2558) which, for this purpose, is longer than the core of the wig-wag pinion (1157).

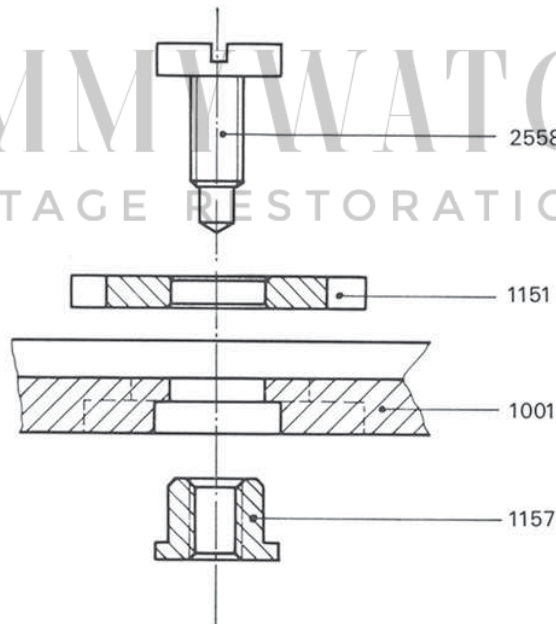

6.1.0. Fitting of the regulator assembly

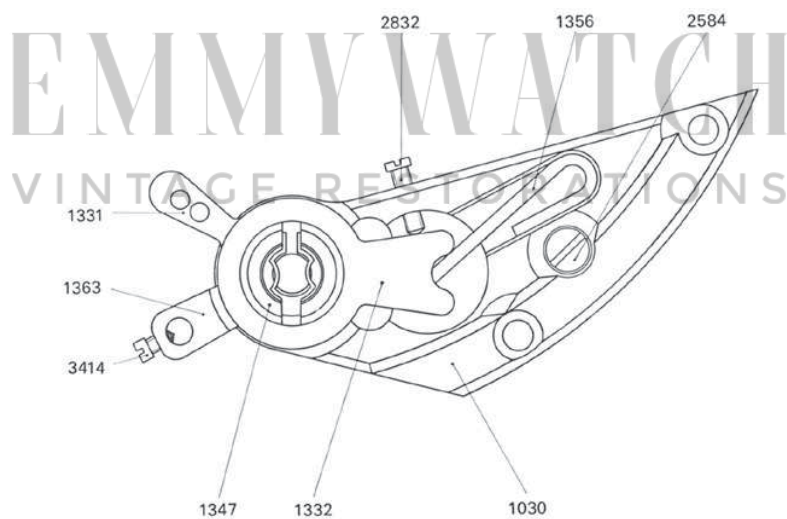
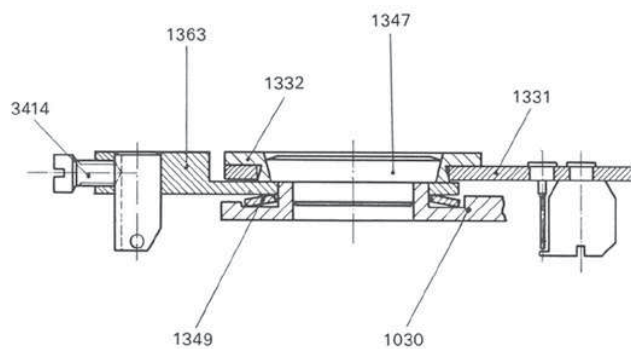

1030 balance cock
 2584 screw for balance cock
 1363 stud-holder
 3414 screw for stud
 1331 regulator (circle)

1332 regulator pointer
 1349 friction gasket for stud-holder
 1347 incabloc upper
 1356 spring for regulator-adjuster
 2832 screw for regulator-adjuster

7.0.0. Wheel train and time display mechanism

Op. No.	Order of assembling operations	Part No.	Fixing device	Lubrication point	code	Remarks
7.0.1.	cannon pinion of third wheel	1230	snap-on			support upper side of pivot
7.0.2.	center cannon pinion	1219		tube	1.00	different for cal. 1010 and 1020
7.0.3.	minute wheel	1246		post	1.00	
7.0.4.	date indicator driving wheel	1560				
7.0.5.	cam for date indicator driving wheel	1562				post in slit of wheel
7.0.6.	day star driving wheel	1571	1 screw 2050			only in cal. 1020 post in hole of cam
7.0.7.	double date setting wheel	1559		post	1.00	
7.0.8.	hour wheel	1232				
7.0.9.	date jumper (and days - cal. 1020)	1503				different for cal. 1010 and 1020
7.0.10.	date jumper spring	1529		funct.	1.00	
7.0.11.	date indicator	1580				
7.0.12.	date indicator guard	1554	3 screws 2585(1010) 2430(1020)			different for cal. 1010 and 1020
7.0.13.	day corrector	7524		pivot	1.00	only in cal. 1020
7.0.14.	day corrector spring	7526				only in cal. 1020
7.0.15.	day star and dial-disc	1516				only in cal. 1020
7.0.16.	day star guard	1555	2 screws 2586			only in cal. 1020

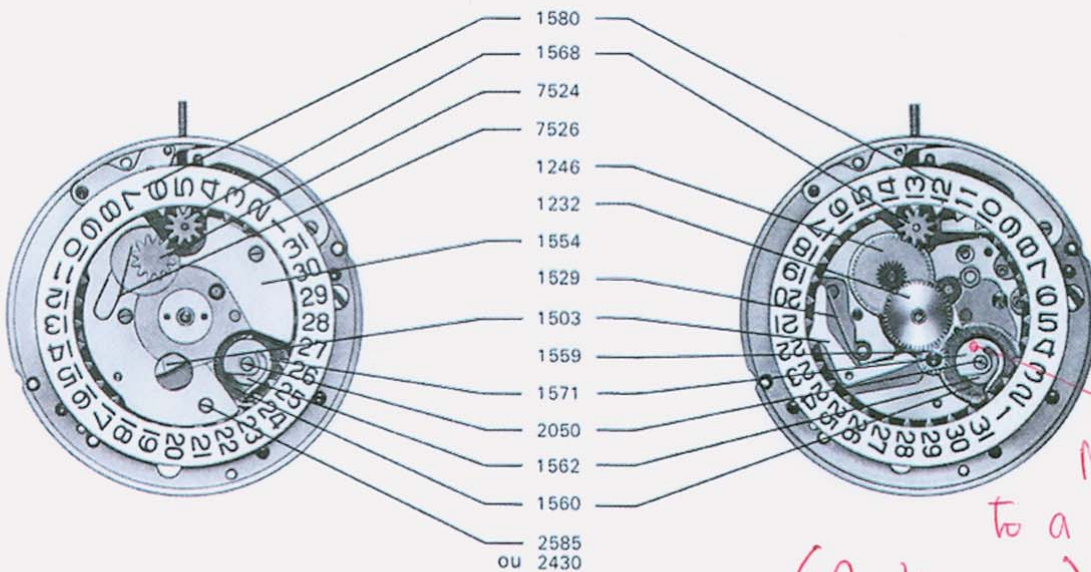

8. 0. 0. Automatic unit

Op. No.	Order of assembling operations	Part No.	Fixing device	Lubrication		Remarks
				point	code	
8.0.1.	driving gear for ratchet wheel	1437		upper lower	1.00	Mounted on the upper bridge for automatic device 1031
8.0.2.	winding gear	1464		upper lower	1.00	
8.0.3.	large connecting pinion for winding wheel	1453		upper lower	1.00	
8.0.4.	small connecting pinion for winding wheel	1454		upper lower	1,00	
8.0.5.	lower bridge for automatic device	1033	2 screws 2584			
8.0.6.	unit on movement		2 screws 2584			
8.0.7.	intermediate connecting pinion for winding wheel	1477				
8.0.8.	rotor	1026		pivot	1.00	
8.0.9.	banking ring for rotor	1478	1 scr. 2578			

EMMYWATCH
VINTAGE RESTORATIONS

