

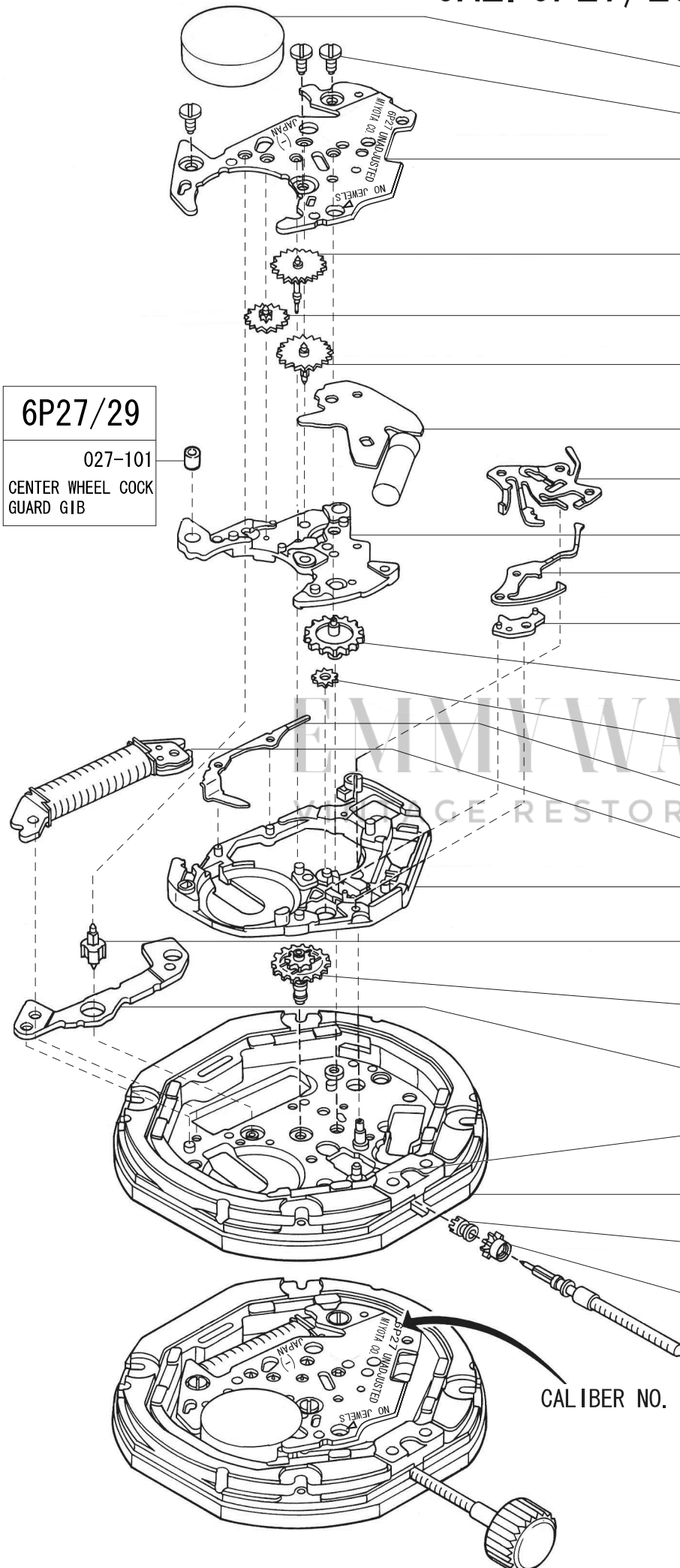









Miyota 6P20,6P21,6P23,6P25,6P27,6P29 Movement Parts (1)

Compiled by EmmyWatch - <https://www.emmywatch.com>

CAL. 6P27/29



6P27/29
027-101
CENTER WHEEL COCK
GUARD GIB









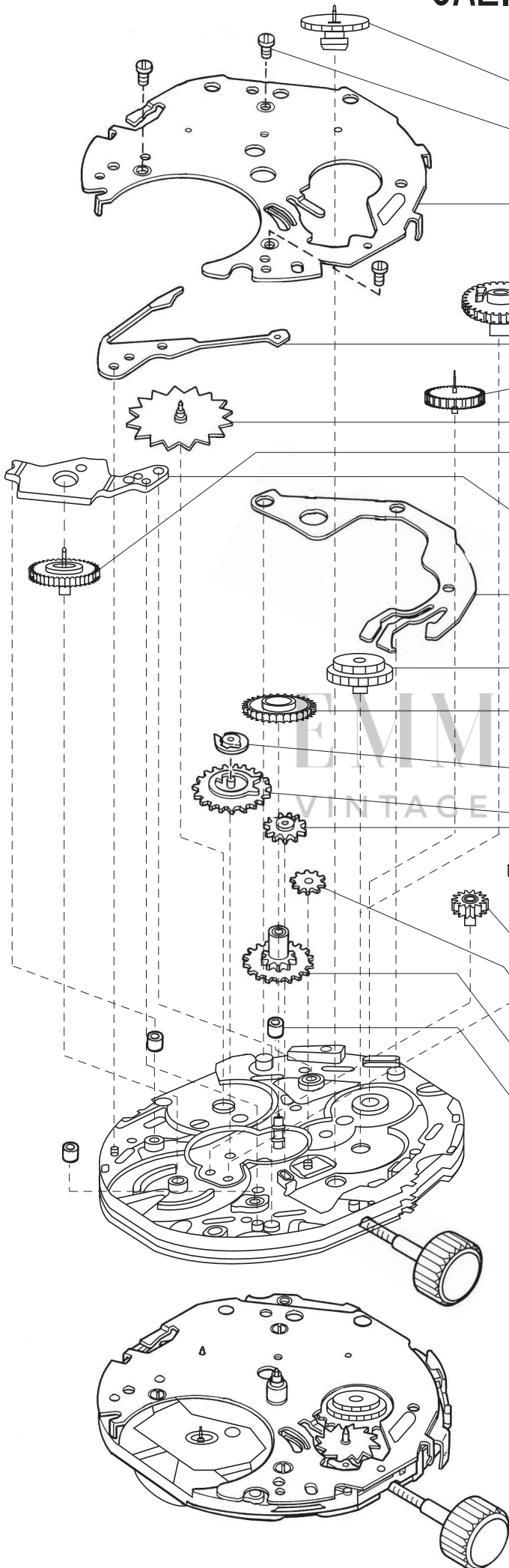





6P27/29	PARTS NAME
280-340	BATTERY
923-810	SCREW FOR TRAIN FOR BRIDGE
701-B86 (6P27) -B87 (6P29)	TRAIN WHEEL BRIDGE
023-205	 4TH WHEEL
084-460	 5TH WHEEL
017-119	 3RD WHEEL
279-735	ELECTRONIC CIRCUIT UNIT
077-109	SETTING LEVER SPRING
711-183	CENTER WHEEL COCK
071-970	YOKE
067-173	SETTING LEVER
072-890	 MINUTE WHEEL
076-640	 SETTING WHEEL
231-163	BATTERY CONNECTOR SPRING
246-121	COIL UNIT
212-146	SPACER FOR SETTING STEM
285-800	 ROTOR
028-196	 CANNON PINION WITH DRAIVING WHEEL
190-790	STATOR
226-307	MAIN PLATE HOLDING FRAME
212-176	DIAL SPACER
064-790	 CLUTCH WHEEL
087-620	INTERMEDIATE DATE CORRECTING WHEEL
065-379	SETTING STEM

CALIBER NO.

☆ 234-513 (POWERCELL STRAP) is a optional part which not equipped with standard movement. it is obtainable on your necessity

CAL. 6P27/29



6P27	6P29	PARTS NAME
—	187-080 	DATE WHEEL
929-520 × 3	←	SCREW FOR CALENDAR GUARD
293-870	←	DIAL WHEEL GUARD
103-950 	—	DATE DIAL DRIVING WHEEL
109-520	←	DATEJUMPER
187-060 	—	DATE WHEEL
200-030 	←	DAY WHEEL
100-350 	←	24 HOUR WHEEL
117-270	←	24 HOUR WHEEL GUARD
—	117-260	DATE CORRECTOR LEVER GUARD
—	100-340 	INTERMEDIATE DATE WHEEL (2)
100-330 	←	INTERMEDIATE DATE WHEEL (1)
106-740 	←	DATE FINGER
103-970 	←	DATE DIAL DRIVING WHEEL
255-340 	←	CALENDAR CORRECTING PILLAR WHEEL
087-101 	←	INTERMEDIATE 24 HOUR WHEEL (2)
087-990 	←	INTERMEDIATE 24 HOUR WHEEL (1)
213-330 	←	DATE CORRECTOR WHEEL
075-328 	←	HOUR WHEEL
027-102 × 3	←	DIAL GUARD GIB