



EMMYWATCH
VINTAGE RESTORATIONS

France Ebauches 5420,5430 Movement Parts (1)

Compiled by EmmyWatch - <https://www.emmywatch.com>



FRANCE ÉBAUCHES

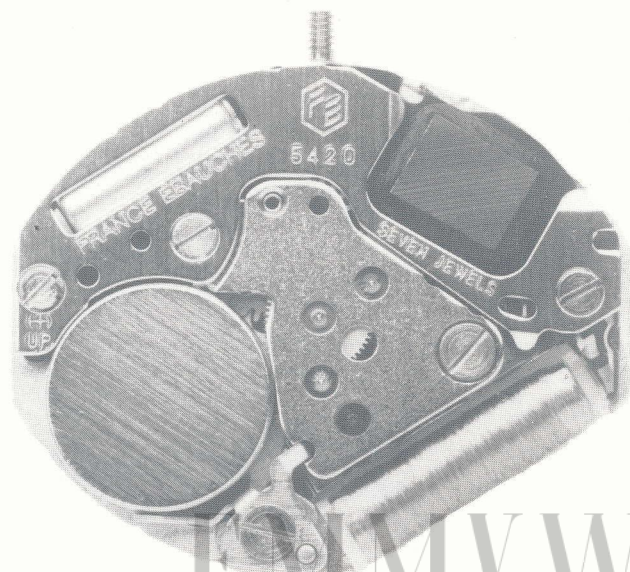

5 1/2 X 6 3/4'''

13,00 X 15,15 mm

FE 5420



FE 5430



EMMYWATCH H= 1,69 mm
VINTAGE RESTORATIONS

CARACTÉRISTIQUES TECHNIQUES	TECHNICAL DATA	TECHNISCHE DATEN	技术资料	mm 毫米
Cage	Frame	Gestell	外架 (框架)	
Dimensions totales	Overall dimensions	Gesamte-Abmessungen	全部大细	13,00 x 15,550
Dimensions encageage	Casins dimensions	Gehäuse-Passung	壳大细	13,00 x 15,150
Hauteur sur filet	Height at bead	Höhe am Wulst	车轮边缘高度	0,500
Hauteur sur tige	Height at stem	Höhe an der Welle	弦杆高度	0,600
Hauteur maximum	Maximum height	Maximale Höhe	最高度	1,690
Tige de mise à l'heure	Hand-setting stem	Stellwelle	机芯止动杆	
Diamètre du filetage	Threading diameter	Gewindedurchmesser	线条直径	0,700
Résonateur	Resonator	Resonator	谐振器	
Fréquence	Fréquency	Frequenz	振荡	32 768 Hz
Moteur	Motor	Motor	电动机	
Nombre d'impulsions	Number of impulses p/minute	Impulszahl p/Minute	每分钟 冲量	60
Exécution : 7 rubis	Version : 7 jewels	Ausführung : 7 Steine	型式: 7 钻 (宝石)	



5420

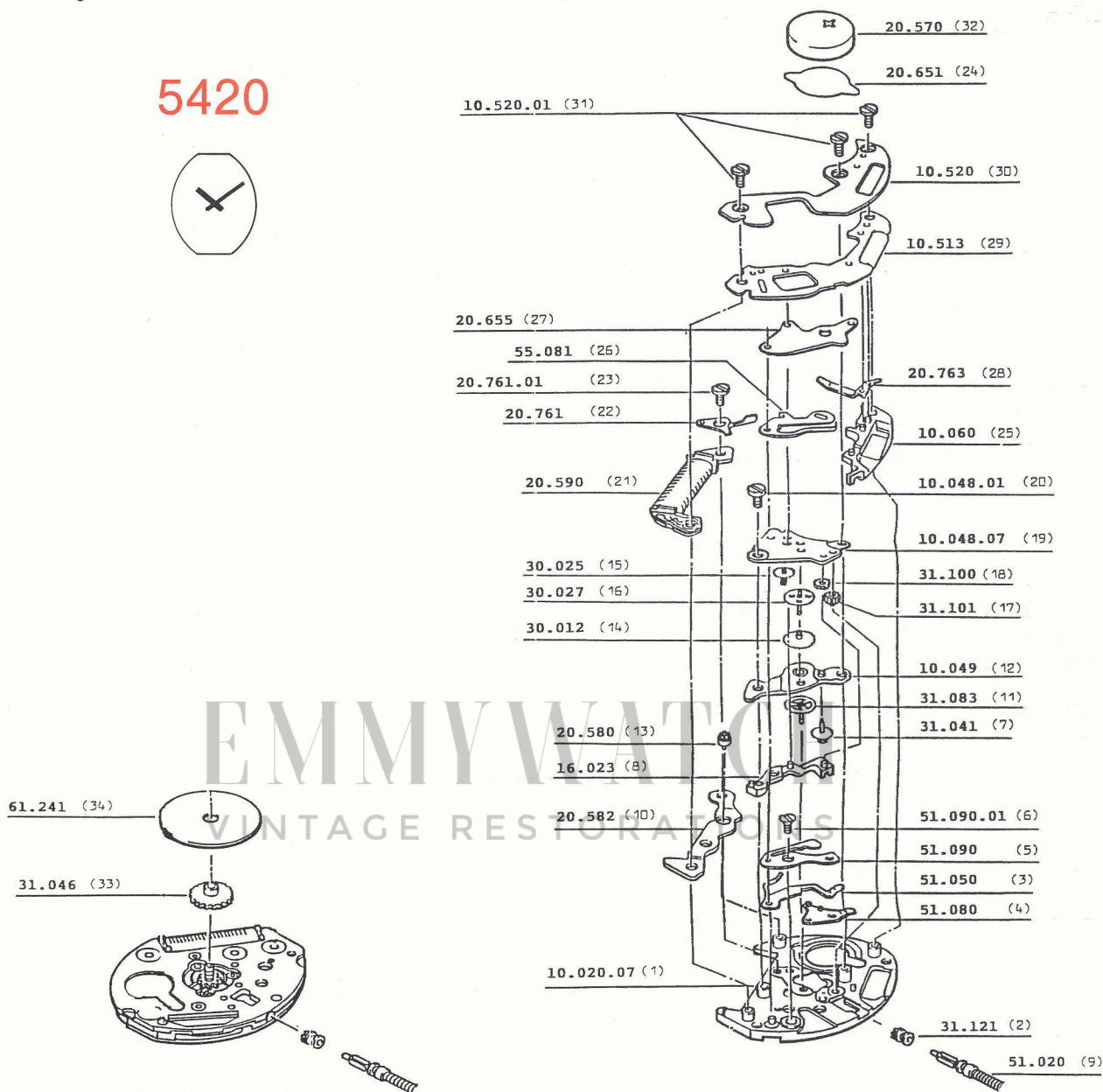

Réf. 编号	Liste des fournitures	List of materials	Bestandteile	零件 名称
10.020.07	100	Platine	Werkplatte	主夹板
10.048.07	110	Pont de rouage	Räderwerkbrücke	系列夹板
10.049	119	Pont inférieur de rouage	Untere Räderwerkbrücke	电子表机芯
10.060	136	Pont de tige	Brücke für zeigerstellwelle	
10.513	4000	Module électronique	Elektronik-Baugruppe	
10.520	4002	bâti de module électrique	Werkgestell für Elektro-Baugruppe	
16.023	9526	Pont de pignon de transmission	brücke für Übertragungstrieb	
20.570	4929	Pile	Batterie	电池
20.580	4211	Rotor	Rotor	转子
20.582	4021	Stator	Stator	定子
20.590	4060	Bobine	Spule	线圈
20.651	4046	Isolateur de pile	Isolation für Batterie	电池绝缘体
20.655	4015	Isolateur de circuit	Isolation für Schaltung	
20.761	4401	Bride +	Bügel +	限位杆
20.763	4402	Contact	Contact	
30.012	203	Roue intermédiaire	Zwischenrad	中间轮
30.025	210	Roue moyenne	kleinbodenrad	三轮
30.027	227	Roue de seconde	Sekundenrad	二轮
31.041	260	Roue de minuterie	Wechselrad	时轮
31.046	250	roue des heures	Stundenrad	分轮部份
31.083	242	Chaussée avec entraîneur	Minutenrohr mit Mitnehmer	带动齿轮
31.100	450	Renvoi	Zeigerstellrad	
31.101	453	Renvoi intermédiaire	Zwischen-Zeigerstellrad	
31.121	407	Pignon coulant	Kupplungstrieb	离合轮
51.020	405	Tige de mise à l'heure	Stellwelle	机芯止动杆

Réf. 编号	Liste des fournitures
51.050	435
51.080	443
51.090	445
55.081	8180
56.071	560
61.241	499
10.048.01	5.110
10.520.01	5.4002
20.761.01	54.401
51.090.01	5.445

Réf. 编号	Pierre de
70.002	603
70.003	604
70.010	605
70.011	606
70.012	612
70.100	-
70.101	-

5430

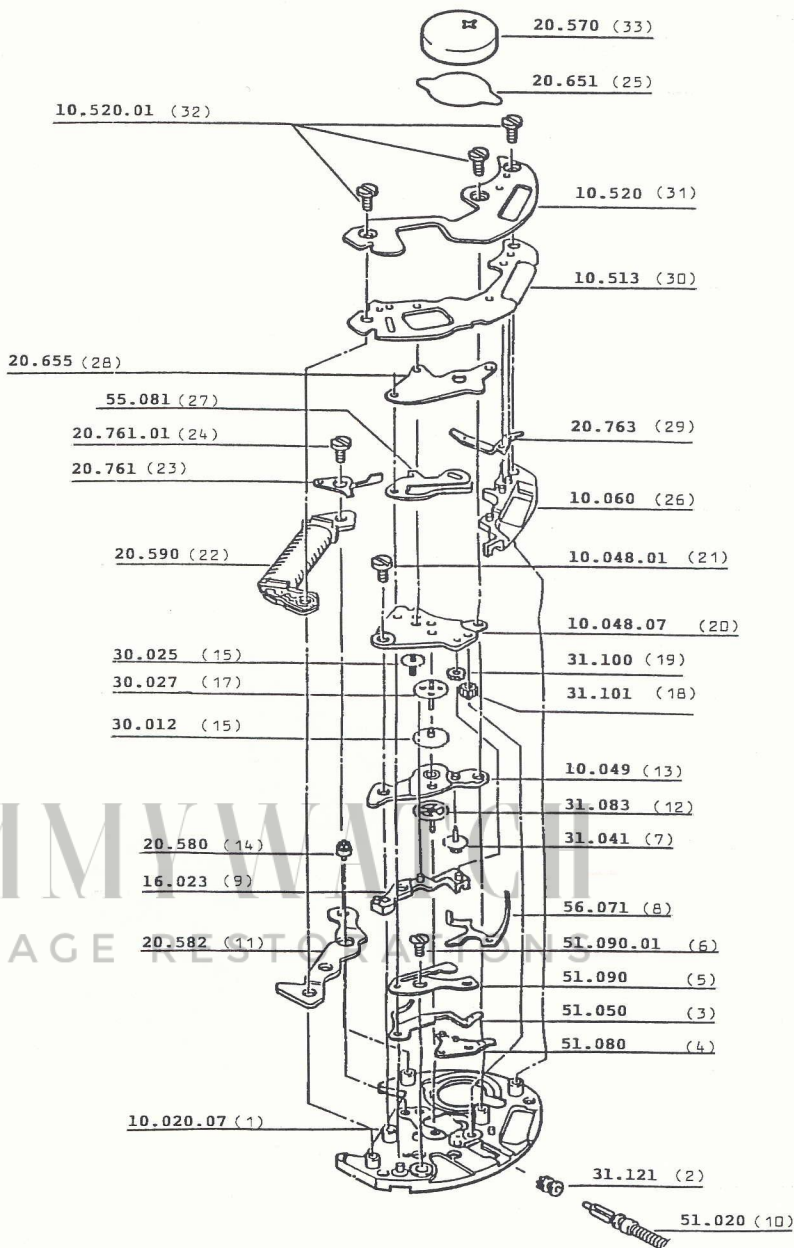

61.241 (35)

31.046 (34)

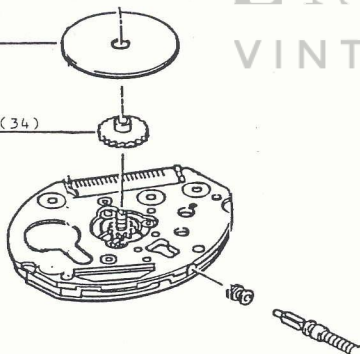

	List of materials	Bestandteile	零件名称
coulant	Yoke-spring Setting lever Setting lever jumper Fly-back yoke	Kupplungstriebhebelfeder Winkelhebel Winkelhebelraste Nullstellerwippe	离合杆 拉档杆
centre	Centre-second stop lever Hour wheel friction spring	Mittelsekunde-Abstelhebel Frikfionsfeder für Stundenrad	中心秒止动杆
crique	Train-wheel bridge screw Electric module framework screw	Räderwerkbrückenschraube Werkgestellschraube für Elektro-Baugruppe	轮系夹板螺钉
	Bridle + screw Setting lever jumper screw	Schraube der Bügel + Winkelhebelrastenschraube	托簧螺钉

Jewel for :	Stein für :	宝石开子	mm : 毫米
Intermediate wheel, top	Zwischenrad, oben	中間輪	上下 14 x 85 x 16
Intermediate wheel, bottom	Zwischenrad, unten	中間輪	上下 14 x 85 x 16
Third wheel, top	Kleinbodenrat, oben	三輪	上下 14 x 85 x 16
Third wheel, bottom	Kleinbodenrat, unten	三輪	上下 14 x 85 x 16
second wheel, top	Sekundenrad, oben	秒輪	上下 14 x 85 x 16
Rotor, top	Rotor, oben	轉子	上下 14 x 85 x 16
Rotor, bottom	Rotor, unten	轉子	上下 14 x 85 x 16

Fonctions de la tige
Handsetting-stem functions
Funktionen der Stellwelle
撥針杆的作用



- 1 - marche normale
- 2 - mise à l'heure, stop-seconde avec interruption du courant pour le moteur

- 1 - regular running
- 2 - handsetting, stop-second with interruption of current to the motor

- 1 - normaler Gang
- 2 - Zeigerstellen, Sekunden-Stopp mit Unterbrechung der Motorspeisung

- 1 - 正常運轉
- 2 - 撥針、中止對電機的電流而停秒

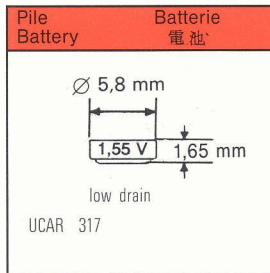

MOEBIUS 8200
Réf. : 51.020 - 51.080 - 31.100 - 31.083

MOEBIUS 9030
Réf. : 10.049 - 31.101 - 10.048.07 - 10.020.07 - 31.041