

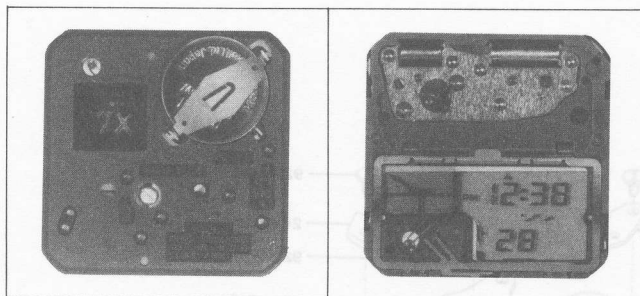

Citizen 8980,8981,8982,8984,8986 Movement Parts (1)

Compiled by EmmyWatch - <https://www.emmywatch.com>

Catalog No. 898-1~898-2



898-1
(Catalog No.)

898-2
(Catalog No.)

8980 · 8981 · 8982 · 8984 · 8986

- Quartz crystal oscillator type
- Analog display and LC digital display
[ANALOG]
 - ANALOG 1
Hour/minute hands with 20-sec. Step movement
Electromagnetic correction system
 - ANALOG 2
Second, Approx. alarm time
Approx local time
Electromagnetic correction system
- [DIGITAL]
 - Time
 - Calendar
 - Thermometer (8980: °C/°F switching function)
 - Temperature memory
 - Dual time function
 - Stopwatch function
 - Chime function
 - Fully automatic calendar (1980~2019)
 - Powercell life indicator
 - Illumination lamp
 - 12/24-hour switching function

Thickness: 4.0mm
(Power cell part 4.2mm)
..... 8980, 8981

Thickness: 3.6mm
(Power cell part 3.9mm)
..... 8982, 8984, 8986

Size: 26mm x 26mm (8980, 8981)
Size: 27.4mm x 31.2mm
(8982, 8984, 8986)

- Cal. 8982 is developed by utilizing the module of Cal. No. 8980 and placing the temperature sensor section inside the case at the bottom of the face (6 Hour mark) of the watch. Cal. 8984 is developed from Cal. 8982 by changing the display section of the LC display panel.
- Cal. 8986 is developed from the Cal. 8982 module, has the color mode mark and numbers in one wide window for the digital section.

Vibrations per second

32,768Hz

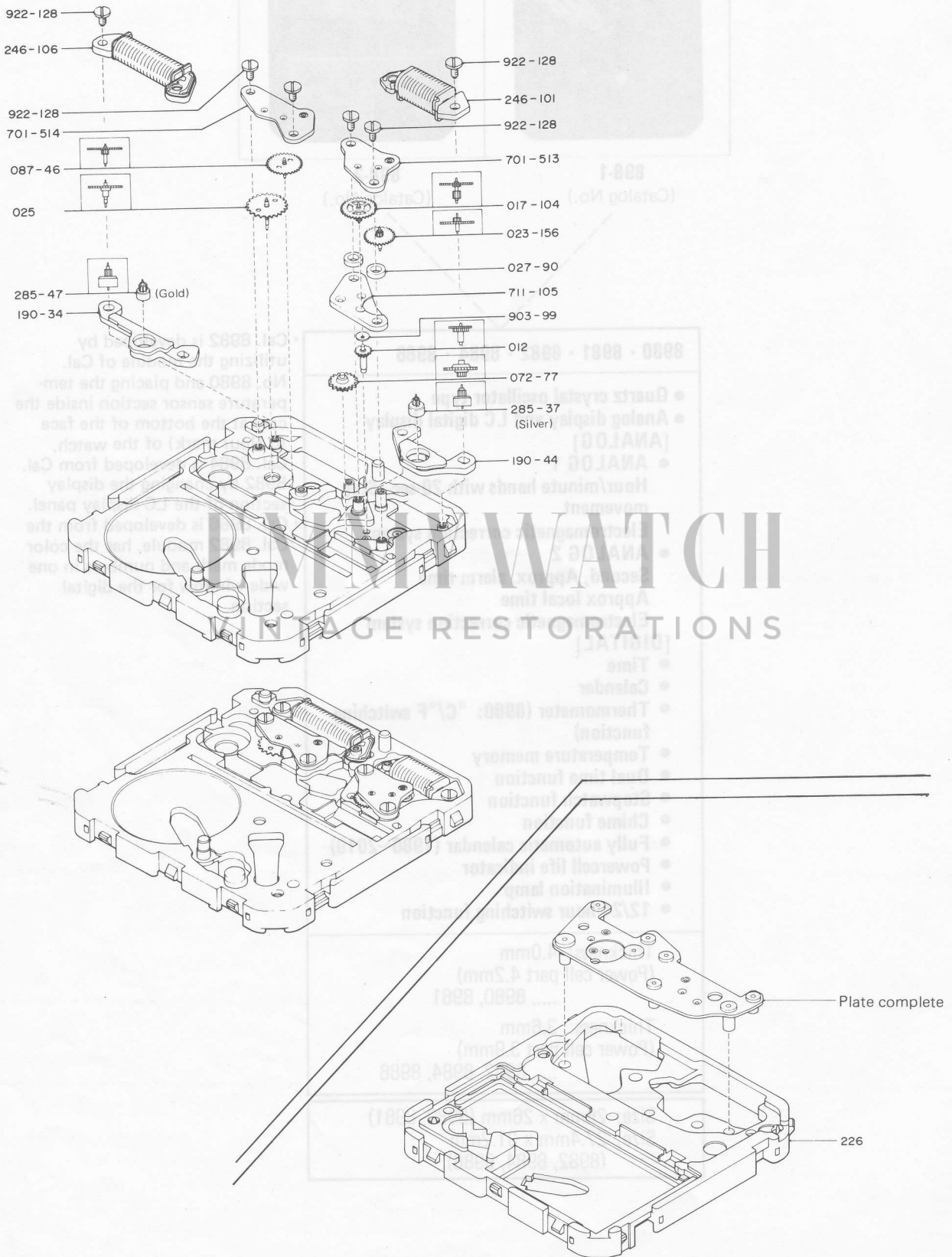

Exploded view of the plate complete

Catalog No. 898-1

Parts No.	Name of parts	Caliber No.				
		8980	8981	8982	8984	8986
		Nos. of jewels				
		04	04	04	04	04
701	Train wheel bridge	513	○	○	○	○
701	Additional train wheel bridge	514	○	○	○	○
711	Center wheel cock	105	○	○	○	○
012	Center wheel and pinion	145	○	○	○	169
017	Third wheel and pinion	104	○	○	○	○
023	Fourth wheel and pinion	156	○	○	○	○
025	Second wheel	69	○	○	○	80
027	Spacer for train wheel bridge	90	○	○	○	○
072	Minute wheel and pinion	77	○	○	○	○
087	Intermediate second wheel	46	○	○	○	○
190	Additional stator	34	○	○	○	○
190	Stator	44	○	○	○	○
226	LC display panel supporter	187	○	293(204)	○	293
246	Coil unit	101	○	○	○	○
246	Additional coil unit	106	○	○	○	○
285	Rotor	37	○	○	○	○
285	Additional rotor	45	○	○	○	○
903	Friction spring for center wheel	99	○	○	○	○
922	Screw for train wheel bridge	128	○	○	○	○
922	Screw for additional train wheel bridge		○	○	○	○
922	Screw for coil unit		○	○	○	○
922	Screw for additional coil unit		○	○	○	○

[Jewels]

Parts No.	Name of parts	Caliber No.				
		8980	8981	8982	8984	8986
		Nos. of jewels				
		04	04	04	04	04
942	Rotor/L	76	○	○	○	○
942	Additional rotor/L		○	○	○	○
942	Rotor/U		○	○	○	○
942	Additional rotor/U		○	○	○	○
950	Third wheel/L	158	○	○	○	○

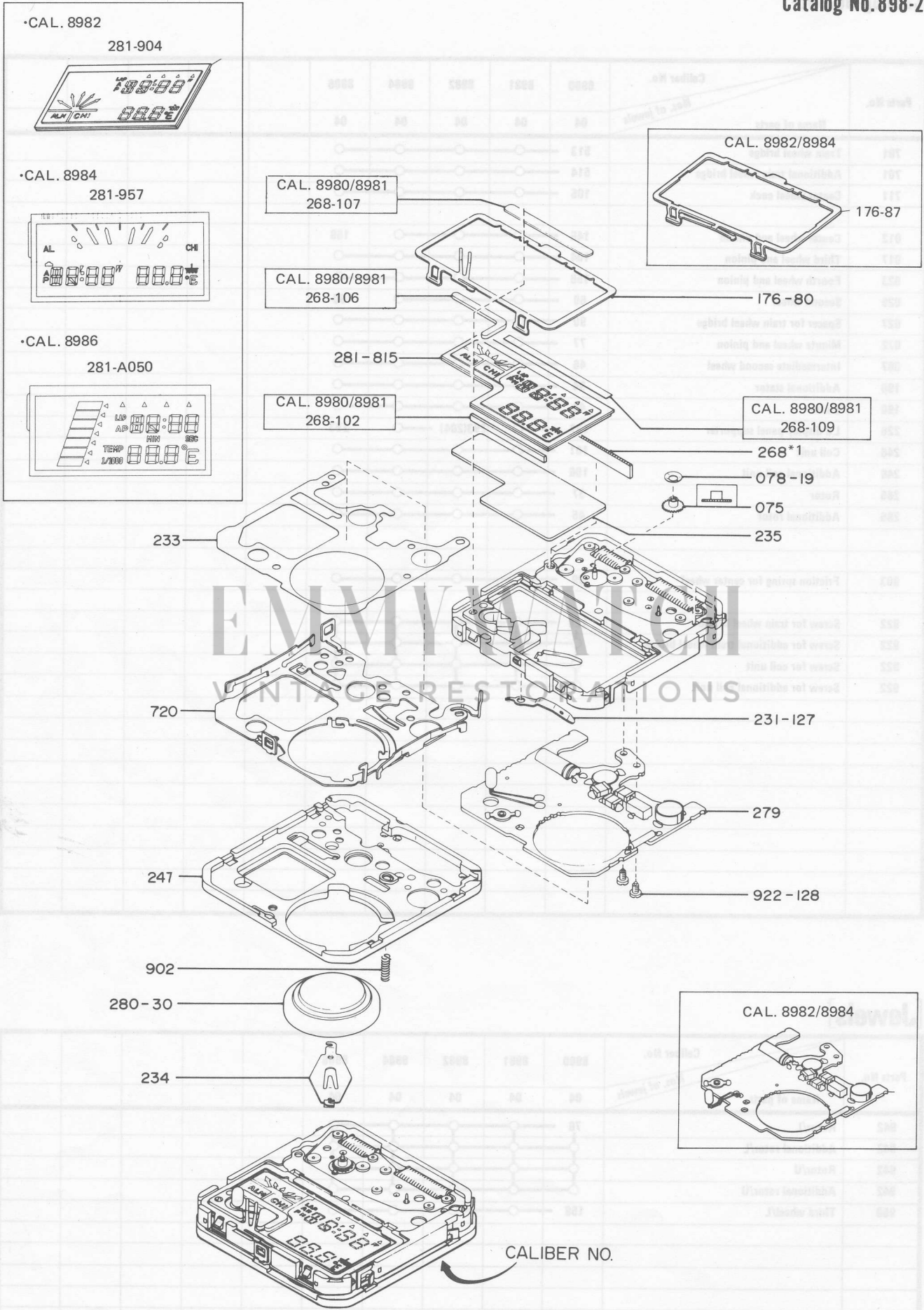

*Please handle the parts marked with * with care.

Catalog No.

Parts No.	Name of parts	Caliber No.										
		8980	8981	8982	8984	8986						
	Nos. of jewels	04	04	04	04	04						
720	Circuit unit supporter	058	—○	065	—○	—○						
212	Dial spacer					133						
075	Hour wheel	194	—○	—○	—○	253						
078	Dial washer	19	—○	—○	—○	—○						
176	LC display panel holder	80	—○	87	—○	—○						
231	Power cell connector spring	127	—○	—○	—○	—○						
233	Insulator sheet	195	—○	226	—○	—○						
234	Power cell strap	358	—○	276	—○	—○						
235	Light diffusing plate (silver)	193	—○	207	218	229						
235	Light diffusing plate (gold)	199	—○	208	219	233						
247	Device cover	319	322	327	336	341						
268	LC display panel connection rubber	96	—○	125	—○	—○						
268	LC display panel supporting rubber	102	—○									
268	Spacer for LC display panel (I)	106	—○									
268	Spacer for LC display panel (II)	107	—○									
268	Spacer for LC display panel (III)	383	394	418	—○	—○						
279	Unit of electronic circuit	109	394	418	—○	—○						
280	Power cell	30	—○	—○	—○	—○						
281	LC display panel	815	—○	904	959	A050						
902	Buzzer contact spring	163	—○	186	—○	—○						
922	Screw for unit of electronic circuit	128	—○	—○	—○	—○						

EMMY WATCH
VINTAGE RESTORATIONS